

BONENG

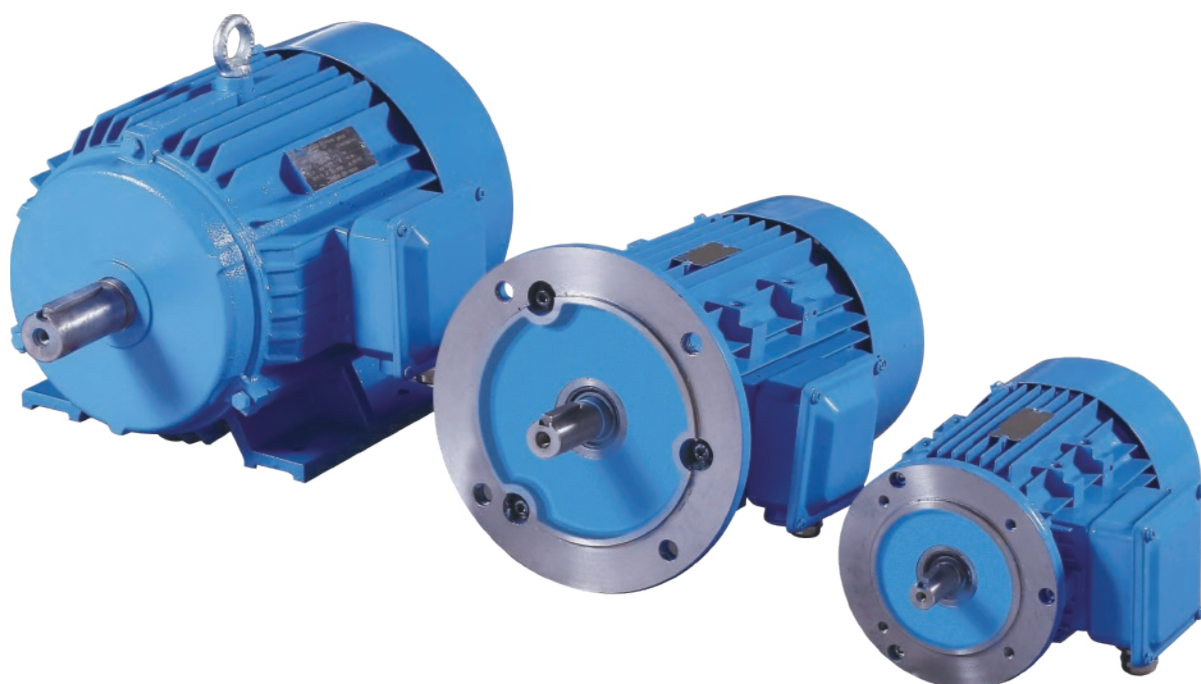

MH/MP Three-Phase Asynchronous Motor

Power: 0.09kW~90kW; Frame Size: 56~280

Modified date 01/2022
Selection Catalogue: C05.0008-EN

Boneng Transmission



Controller/ Drive/ Motor/ Gearmotor/ Gearbox

Notes:

- ◆ The structure scheme, appearance diagram and other attached diagrams in sample are examples, there is no strict proportion requirement. (The unmarked dimension units are mm).
- ◆ The marked weight is average value, it has no constraint force.

The following items must be strictly observed:

- ◆ To prevent accidents, all the rotation parts are added with protective covers by the purchaser according to the safety regulations of the nation and region.
- ◆ The instruction book must be read carefully before the test run.

Contents

01.Overview	01
02.Reference standards	04
03.Mechanical design	05
04.Electrical design	08
05.Options	10
06.Frequency conversion applications	14
07.MH/MP motor type Designation	15
08.MH motor selection technical data(IE2 Energy Efficiency)	17
09.MP motor selection technical data(IE3 Energy Efficiency)	21
10.MH motor dimensions	25
11.MP motor dimensions	29
12.Dimensions of motor shaft projecting tail and rainproof cover	32
13. Electrical connection schematics	33

1 Overview

BONENG three-phase asynchronous motor is a universal closed-fan cooling or forced-cooled three-phase asynchronous motor, the standard protection class IP55, the design and production in line with IEC, GB and other related standards. Apply to continuous work system (S1), constant speed or speed within a certain range of frequency control applications, but also to meet most of the intermittent work (S2-S10), constant speed or speed within a certain range of frequency control applications.

1.1 Technical Design

- ◆ Frame material: H56-100: Die-casting aluminum;
H112-280: grey cast iron;
- ◆ Rated power: 0.09 kW-90 kW。
- ◆ Number of motor poles: 4,6
- ◆ Motor efficiency: Meet the IEC 60034-30 standard IE3, IE2 efficiency level, and to Meet GB18613-2020 standard energy efficiency grade 3.
- ◆ Standard mounting structure (Compliance with standards IEC 60034-7) : IMB3、IMB5、IMB14B、IMB35、IMB34B, etc.
- ◆ Motor Degree of Protection: Protection class IP55 (IEC 60034-5).
- ◆ Motor Insulation class: Insulation system designed according to the temperature level of 155 °C (F), by 130 (B) temperature level assessment, H-class insulation (optional); The temperature rise limits according to IEC 60034-1 are as follows (resistance method).

Insulation class	Temperature rise level (K)		
	Thermometer method	Resistance method	Embedded thermometer method
B	70	80	85
F	85	100	105
H	105	125	130

- ◆ Motor thermal protection: Optional PTC thermistor, thermal switch or PT100 temperature sensor for winding protection.
- ◆ Motor terminal box: From the motor tail, the standard position of the terminal box is on the left side of the frame, with the cable entry facing down. Terminal box location and cable entry can be selected according to the customer requirements.
- ◆ Motor terminal box cable entry: Motor cable entry H56-80 for one, H90-280 for two.
- ◆ Motor cooling method :Motor cooling is radial-flow fans cooled (IC 411 as specified in IEC 60034-6) and provide the motor that independently drives fan for forced cooling and natural cooling.

1.2 Operating environment

- ◆ Motor standard operating environment
 - Operating altitude does not 1000m above sea level (IEC 60034-1) ;
 - Allowable working environment temperature -20°C-40°C (IEC 60034-1) ;
 - Permitted relative humidity:
 - 20°C ≤ T ≤ 20°C: 100%
 - 20°C < T ≤ 30°C: 95%
 - 30°C < T ≤ 40°C: 55%
- ◆ For higher ambient temperatures and / or locations 1000 m above sea level, the specified motor output must be reduced by using the factor K_{HT} . The results in an admissible output (P_{adm}) of the motor: $P_N' : P_N' = P_N \cdot K_{HT}$

Factor K_{HT} for different side altitudes and / or ambient temperature

Altitude above sea level	Ambient temperature					
	<30°C	30~40°C	45°C	50°C	55°C	60°C
1000 m	1.07	1	0.96	0.92	0.87	0.82
1500 m	1.04	0.97	0.93	0.89	0.84	0.79
2000 m	1	0.94	0.9	0.86	0.82	0.77
2500 m	0.96	0.9	0.86	0.83	0.78	0.74
3000 m	0.92	0.86	0.82	0.79	0.75	0.7
3500 m	0.88	0.82	0.79	0.75	0.71	0.67
4000 m	0.82	0.77	0.74	0.71	0.67	0.63

1.3 Nameplate information

2		3		4		5		6		1													
BONENG												三相异步马达 MPI12L4B40FC3											
112L-4		B5		IP55		Ins. F		S1															
kW		V		Hz		A		r/min		Conn.		COS φ		EFF		IE-CL							
4		380/660		50		8.4/4.9		1450		△/Y		0.82		88.6%		IE3							
		440		60		7.3		1755		△		0.82		89.5%		IE3							
Q/320507		LGM32-2020		56 kg		Date 202001		NO. 12345678															
BONENG TRANSMISSION (SUZHOU) CO., LTD																							
8		9		10		11		17		12		13		18		14		15		19		16	

2		3		4		5		6		1													
BONENG												3-Mot. MPI12L4B40FC4											
112L-4		B5		IP55		Ins. F		S1															
kW		V		Hz		A		r/min		Conn.		COS φ		EFF		IE-CL							
4		400/690		50		8.2/4.7		1455		△/Y		0.81		88.6%		IE3							
		460		60		7.3		1760		△		0.8		89.5%		IE3							
Q/320507		LGM32-2020		56 kg		Date 202001		NO. 12345678															
BONENG TRANSMISSION (SUZHOU) CO., LTD																							
8		9		10		11		17		12		13		18		14		15		19		16	

2		3		4		5		6		1		20															
BONENG												3-Mot. MPI12L4B40FC4															
112L-4		B5		IP55		Ins. F		S1		Brake 180VDC/60N.m																	
kW		V		Hz		A		r/min		Conn.		COS φ		EFF		IE-CL											
4		400/690		50		8.2/4.7		1455		△/Y		0.81		88.6%		IE3											
		460		60		7.3		1760		△		0.8		89.5%		IE3											
Q/320507		LGM32-2020		65 kg		Date 202001		NO. 12345678																			
BONENG TRANSMISSION (SUZHOU) CO., LTD																											
8		21		9		10		11		17		12		13		18		14		22		15		19		16	

1. Motor type (specification)
2. Frame size
3. Type of construction
4. Degree of protection
5. Insulation Class
6. Duty
7. Enterprise standard
8. Rated power
9. Rated voltage
10. Rated frequency
11. Rated current
12. Rated speed
13. Winding connections
14. Power factor
15. Efficiency
16. Energy efficiency class
17. Weight
18. Date of manufacture
19. Number of manufacture
20. Braking voltage / torque
21. Constant torque Range
22. Constant power Range

1.4 Motor Energy Efficiency

- ◆ According to IEC 60034-30-1 standard, the scope of motor energy efficiency is:
 - Motor under 1000V, 50 / 60Hz three-phase AC power supply;
 - 2,4,6,8 pole single-speed motor with power of 0.12 kW ~ 1000kW;
 - N designed continuous working system (S1) motor.
- ◆ IEC60034-30-1 Energy efficiency rating:

IEC 60034-30-1	GB18613-2020
IE2	/
IE3	Grade 3 Energy Efficiency
IE4	Grade 2 Energy Efficiency
IE5	Grade 1 Energy Efficiency

IEC60034-30-1标准, 马达能效 (η %) :

功率 (KW)	IE2-50Hz		IE3-50Hz		IE4-50Hz	
	4极	6极	4极	6极	4极	6极
0.12	59.1	50.6	64.8	57.7	69.8	64.9
0.18	64.7	56.6	69.9	63.9	74.7	70.1
0.2	65.9	58.2	71.1	65.4	75.8	71.4
0.25	68.5	61.6	73.5	68.8	77.9	74.1
0.37	72.7	67.6	77.3	73.5	81.1	78
0.4	73.5	68.8	78	74.4	81.7	78.7
0.55	77.1	73.1	80.8	77.2	83.9	80.9
0.75	79.6	75.9	82.5	78.9	85.7	82.7
1.1	81.4	78.1	84.1	81	87.2	84.5
1.5	82.8	79.8	85.3	82.5	88.2	85.9
2.2	84.3	81.8	86.7	84.3	89.5	87.4
3	85.5	83.3	87.7	85.6	90.4	88.6
4	86.6	84.6	88.6	86.8	91.1	89.5
5.5	87.7	86	89.6	88	91.9	90.5
7.5	88.7	87.2	90.4	89.1	92.6	91.3
11	89.8	88.7	91.4	90.3	93.3	92.3
15	90.6	89.7	92.1	91.2	93.9	92.9
18.5	91.2	90.4	92.6	91.7	94.2	93.4
22	91.6	90.9	93	92.2	94.5	93.7
30	92.3	91.7	93.6	92.9	94.9	94.2
37	92.7	92.2	93.9	93.3	95.2	94.5
45	93.1	92.7	94.2	93.7	95.4	94.8
55	93.5	93.1	94.6	94.1	95.7	95.1
75	94	93.7	95	94.6	96	95.4
90	94.2	94	95.2	94.9	96.1	95.6
110	94.5	94.3	95.4	95.1	96.3	95.8
132	94.7	94.6	95.6	95.4	96.4	96
160	94.9	94.8	95.8	95.6	96.6	96.2
200	95.1	95	96	95.8	96.7	96.3
250	95.1	95	96	95.8	96.7	96.5
315-1000	95.1	95	96	95.8	96.7	96.6
功率 (KW)	IE2-60Hz		IE3-60Hz		IE4-60Hz	
	4极	6极	4极	6极	4极	6极
0.12	64	50.5	66	64	70	68
0.18	68	55	69.5	67.5	74	72
0.25	70	59.5	73.4	71.4	77	75.5
0.37	72	64	78.2	75.3	81.5	78.5
0.55	75.5	68	81.1	81.7	84	82.5
0.75	82.5	80	85.5	82.5	85.5	84
1.1	84	85.5	86.5	87.5	87.5	88.5
1.5	84	86.5	86.5	88.5	88.5	89.5
2.2	87.5	87.5	89.5	89.5	91	90.2
3.7	87.5	87.5	89.5	89.5	91	90.2
5.5	89.5	89.5	91.7	91	92.4	91.7
7.5	89.5	89.5	91.7	91	92.4	92.4
11	91	90.2	92.4	91.7	93.6	93
15	91	90.2	93	91.7	94.1	93
18.5	92.4	91.7	93.6	93	94.5	94.1
22	92.4	91.7	93.6	93	94.5	94.1
30	93	93	94.1	94.1	95	95
37	93	93	94.5	94.1	95.4	95
45	93.6	93.6	95	94.5	95.4	95.4
55	94.1	93.6	95.4	94.5	95.8	95.4
75	94.5	94.1	95.4	95	96.2	95.8
90	94.5	94.1	95.4	95	96.2	95.8
110	95	95	95.8	95.8	96.2	96.2
150	95	95	96.2	95.8	96.5	96.2
185	95	95	96.2	95.8	96.5	96.2
220	95.4	95	96.2	95.8	96.8	96.5
250-335	95.4	95	96.2	95.8	96.8	96.5
375-1000	95.8	95	96.2	95.8	96.8	96.5

2 Reference standards

Name	IEC standard	Chinese national standard
Rotating electrical machines-Rating and performance	IEC 60034-1	GB 755
Test procedures for three-phase induction motors	IEC 60034-2	GB/T 1032
Classification of degrees of protection provided by enclosures of rotating electrical machines (IP code)	IEC 60034-5	GB/T 4942.1
Cooling methods of rotating electrical machines	IEC 60034-6	GB/T 1993
Classification of types of construction and mounting arrangements for rotating electrical machines (IM code)	IEC 60034-7	GB/T 997
Rotating electrical machines —Terminal marking and direction of rotation	IEC 60034-8	GB/T 1971
Measurement of airborne noise emitted by rotating electrical machines and the noise limits - Part 3:Noise limits	IEC 60034-9	GB/T 10069.3
Mechanical vibration of certain machines with shaft heights 56 mm and higher-measurement ,evaluation and limits of vibration severity	IEC 60034-14	GB/T 10068
Dimensions and output series for rotating electrical machines--Part 1:Frame numbers 56 to 400 and flange numbers 55 to 1080	IEC 60072-1	GB/T 4772.1
General requirements for safety of small and medium size rotating electrical machines	/	GB/T 14711
Electrical insulation—Thermal evaluation and designation	IEC 60085	GB/T 11021
Environmental conditions appearing in nature of electric and electronic products Temperature and humidity	IEC 60721-2-1	GB/T 4797.1
Standard Voltages	IEC 60038	GB/T 156

3 Mechanical design

3.1 Terminal box

- The terminal box is self-rotating by $4 \times 90^\circ$, allowing cables to enter in all directions. 56–80 motor terminal box has one cable entry using gland seal, 90–280 motor terminal box has two cable entries, one of the cable entry with gland seal, the other cable entry using plug seal.
- Motor terminal box technical parameters see the table below:

Frame size	Numbers of main terminals	Contact screw thread	Outer cable diameter (mm)	Cable entry size (gland +screwed plug)
56	6	M4	9~15	M25×1.5
63				
71				
80				
90	6	M4	9~15	M25×1.5+M25×1.5
100	6	M4	9~15	
112	6	M5	14~20	M30×2+M30×2
132				
160	6	M6	18~24	M36×2+M36×2
180				
200	6	M8	24~32	M48×2+M48×2
225				
250	6	M10	37~44	M64×2+M64×2
280				

3.2 Type of construction

Basic construction	Frame with feet	Cover with flange	Cover with small flange	Cover with flange Frame with feet	Cover with small flange Frame with feet
Frame size	63-280	63-280	71-132	63-280	71-132
Mounting type	IMB3	IMB5	IMB14B	IMB35	IMB34B
Diagram					

3.3 Motor shaft end thread

Frame size	Drive end	Non-drive end
63	CM4L10/7.4	CM4L10/7.4
71	CM5L10/8.8	CM5L10/8.8
80	CM6L12/10.5	CM8L12/13.2
90	CM8L12/13.2	
100	CM10L15/16.3	
112	CM12L20/19.8	CM10L15/16.3
132		CM10L15/16.3
160	CM16L25/25.3	CM16L25/25.3
180		CM16L25/25.3
200-280	CM20L30/31.3	CM20L30/31.3

3.4 Bearing

BONENG motor is using deep groove ball bearings for the standard configuration, these bearings are sealed. Bearing specifications are as follows:

Frame size	Standard motor bearing specifications	
	Drive end	Non-drive end
56-63	6201-2Z/C3	6201-2Z/C3
71	6202-2Z/C3	6202-2Z/C3
80	6204-2Z/C3	6204-2Z/C3
90	6205-2Z/C3	6304-2Z/C3
100	6206-2Z/C3	6206-2Z/C3
112	6306-2Z/C3	6206-2Z/C3
132	6308-2Z/C3	6208-2Z/C3
160	6309-2Z/C3	6209-2Z/C3
180	6311-2Z/C3	6211-2Z/C3
200	6312-2Z/C3	6212-2Z/C3
225	6313-2Z/C3	6312-2Z/C3
250	6314-2Z/C3	6314-2Z/C3
280	6317-2Z/C3	6316-2Z/C3

Bearing life

The nominal bearing life can be calculated according to the standard calculation procedures specified in ISO 281. If the motor is operated under the conditions specified in this catalog, 90% or more of the bearings will reach the nominal life. Generally, the service life of a bearing depends on the bearing specification, bearing loaded, operating conditions, rotational speed, and grease life. When the motor is installed horizontally and without axial force, the bearing life of the motor can reach at least 40,000 hours. In the case of maximum allowable load, the life of the motor is at least 20,000 hours. The bearing life here refers to the normal operation of the motor at 50/60Hz.

When the motor is operating under abnormal conditions, the bearing life will be shortened. Such as the following situations:

- ◆ When the motor speed is higher than the rated speed, due to increased vibration of the motor, making the bearing subjected to additional radial and axial forces, resulting in reduced life expectancy;
- ◆ When the environment or equipment and other factors lead to increased vibration of the motor, the bearing will therefore be subjected to additional radial and axial forces, resulting in reduced life expectancy;
- ◆ When the ambient temperature increases 10 °C, grease life and relubrication time will be cut in half.

3.5 Noise

Motor noise is divided into N level (general level), R level (first level), S level (excellent level) and E level (low noise level) four levels. R is lower than the level N level 5dB, S level is lower than the level N 10dB, E level lower than the level N 15dB. BONENG general series of motor noise values are lower than the N-class noise level.

◆ The noise value of A weighted sound power level measured when the motor is not loaded:

Motor Power (KW)	Synchronous speed (r/min)	
	1500/1800	1000/1200
	Sound power level dB(A)	
0.12	52	/
0.18	52	52
0.25	55	52
0.37	55	54
0.55	58	54
0.75	58	57
1.1	61	57
1.5	61	61
2.2	64	65
3	64	69
4	65	69
5.5	71	69
7.5	71	73
11	75	73
15	75	73
18.5	76	76
22	76	76
30	79	76
37	81	78
45	81	80
55	83	80
75	86	85
90	86	85

◆ A weighted sound power level noise increase measured at motor load:

Motor Power (KW)	Synchronous speed (r/min)	
	1500/1800	1000/1200
	Sound power level dB(A)	
≤11	5	7
>11~37	4	6
≥37~90	3	5

3.6 Vibration

Motor vibration levels are divided into N level (conventional level), R level (lower level) and S level (special level). BONENG motor rotors are half-key balancing, in line with N class IEC60034-14 vibration level. For applications requiring lower vibrations, we can offer motors with lower R or S vibration requirements.

Vibration level	Speed (r/min)	Frame size		
		56-132	160-225	250-280
N	600-3600	1.8mm/s	2.8 mm/s	3.5 mm/s
R	600-1800	0.71 mm/s	1.12 mm/s	1.8 mm/s
	>1800-3600	1.12 mm/s	1.8 mm/s	2.8 mm/s
S	600-1800	0.45 mm/s	0.71 mm/s	1.12 mm/s
	>1800-3600	0.71 mm/s	1.12 mm/s	1.8 mm/s

4 Electrical design

4.1 Voltage/Frequency

IEC 60034-1 classifies voltage and frequency variations into Class A ($\pm 5\%$ voltage deviation, $\pm 2\%$ frequency deviation) and class B ($\pm 10\%$ voltage deviation, $\pm 3\%$ /-5% frequency deviation). Motors are rated for class A and class B torque. In class A, the temperature is about 10 K higher than during normal operation.

Standard 60034-1	Class A	Class B
Voltage deviation	$\pm 5\%$	$\pm 10\%$
Frequency deviation	$\pm 2\%$	$\pm 3\%$ /-5%

4.2 Electrical parameter tolerances

- ◆ Efficiency η
 - $P \leq 150 \text{ kW}$: $-0.15 (1 - \eta)$
 - $P > 150 \text{ kW}$: $-0.10 (1 - \eta)$
 - Efficiency η is a value less than one
- ◆ Power factor: $(1 - \cos \phi) / 6$
 - Minimum absolute value: 0.02
 - maximum absolute value: 0.07
- ◆ Slip rate: $\pm 20\%$ (When motor power $< 1 \text{ kW}$, deviation $\pm 30\%$ is allowed)
- ◆ Locked-rotor motor current: $+20\%$
- ◆ Locked-rotor torque: -15% - $+25\%$
- ◆ Maximum torque: -10%
- ◆ Rotational inertia: $\pm 10\%$

4.3 Overload

According to standard IEC60034, BONENG motors can withstand 1.5 times the rated current at rated voltage and frequency for 2 minutes without damage .

4.4 Insulation system

BONENG motors insulation system with reliability, durability and long life, impact resistance and strong features. BONENG motors standard design temperature is class F (155 °C), optional temperature class H (180 °C).

4.5 Duty

The duty is a description of some of the column load conditions that the motor is subjected to, including starting, Electric brake, no-load, downtime , power-off, duration and sequencing. Work system is divided into 10 categories, see the table below:

Duty	Meaning
S1	Continuous duty: Constant load operation, the motor reaches the state of thermal stability.
S2	Short-time duty: constant load for a predetermined limited time, and then stop the motor until it returns to ambient temperature.
S3	Intermittent periodic duty :start-up process has no effect on temperature rise. Run in the same series of work cycles.
S4-S10	Intermittent duty: Start-up process has an impact on temperature rise, operation consists of a series of the same cycle, each cycle includes the dead load section and no-load and energy-cut section. It can use load continuation cdf and start and stop every hour to describe.

4.6 Load factor

Load Continuity is the ratio of load duration to duty cycle duration. The duty cycle time is the sum of the running time plus the break time. $Cdf = \text{sum of one cycle run time} / \text{work cycle time} * 100\%$. Our general series of motor work system are S1, if S1 working system motor use at S2 or S3 working system, allowing the output power should be the product of the rated power and power growth factor K. The growth factors are as follow:

Duty		Power growth factor K	
S2	operation hours	60 min	1.1
		30 min	1.2
		10 min	1.4
S3	load factor (cdf)	60%	1.1
		40%	1.15
		25%	1.3
		15%	1.4
S4-S10	In order to determine the rated power and working system, it is necessary to give start and stop numbers per hour, start and stop mode, load time, brake type, braking time and no-load power-off time.	Please consult separately	

4.7 Degree of protection

BONENG motor protection strict implementation of IEC60034–5 related standards, our production of the motor protection is IP55 as a standard configuration, according to customer needs we can also provide a higher degree of protection of the motor.

IP	First characteristic numeral	Second characteristic numeral
	Protection against solid objects	Protection against liquid
0	No special protection	No special protection
1	Protected against solid objects greater than 50mm	Protected against dripping water
2	Protected against solid objects greater than 12mm	Protected against dripping water when tilted up to 15°
3	Protected against solid objects greater than 2.5mm	Protected against spraying water
4	Protected against solid objects greater than 1mm	Protected against splashing water
5	Dust-protected	Protected against water jets
6	Dust-tight	Protected against heavy seas
7	/	Protected against the effects of immersion
8	/	Protected against the effects of continuous submersion

5 Options

5.1 Cooling and ventilation

BONENG motors are equipped with a radial cooling fan as standard and their cooling performance is independent of the direction of rotation of the motor (The cooling method is IC411,meets the IEC60034–6 standard). For some applications, you can consider use separate drive fans such as:

- ◆ Motor is running at low speed, separately driven fan is recommended, so that the motor can be used efficiently.
- ◆ When the motor is operated at a speed obviously higher than the rated synchronous speed, it is also recommended to use a separate drive fan, which helps to reduce the motor noise.
- ◆ Cooling method:
 IC410 motor surface self-cooling
 IC411 motor surface self-fan cooling
 IC416 motor surface independent fan forced cooling
 With independent drive fan, you must select the appropriate fan parameter configuration according to needs.
- ◆ Independent fan technical data

Frame size	Type	Voltage (V)	Frequency (Hz)	Power (W)	Current (A)	Speed (r/min)
063	G63	400 / 460	50 / 60	24 / 32	0.065 / 0.07	2800 / 3400
071	G71	400 / 460	50 / 60	35 / 36	0.1 / 0.072	2800 / 3300
080	G80	400 / 460	50 / 60	37 / 38	0.1 / 0.08	2700 / 3400
090	G90	400 / 460	50 / 60	45 / 40	0.1 / 0.08	2500 / 3200
100	G100	400 / 460	50 / 60	45 / 70	0.1 / 0.13	2750 / 3250
112	G112	400 / 460	50 / 60	50 / 80	0.1 / 0.13	2750 / 3200
132	G132	400 / 460	50 / 60	40 / 50	0.13 / 0.15	1450 / 1700
160	G160	400 / 460	50 / 60	70 / 100	0.13 / 0.15	1350 / 1550
180	G180	400 / 460	50 / 60	70 / 100	0.13 / 0.15	1350 / 1550
200	G200	400 / 460	50 / 60	180 / 270	0.36 / 0.45	1250 / 1350
225	G225	400 / 460	50 / 60	200 / 280	0.36 / 0.45	1200 / 1300
250	G250	400 / 460	50 / 60	400 / 600	0.9 / 1.0	1300 / 1400
280	G280	400 / 460	50 / 60	450 / 600	0.9 / 1.0	1250 / 1400

5.2 Encoder

BONENG motor can be connected with the encoder to achieve speed closed-loop control, the encoder has the characteristics of high resolution ,high control accuracy and reliable operation.

◆ Encoder electrical parameters

Encoder type	High-performance encoder with HTL	Cost-effective encoder with HTL	High-performance encoder with TTL
Voltage	10-30V	10-30V	5-30V
Signal output form	push-pull	push-pull	RS422
Resolution	1024	1024	1024
Maximum output frequency	300KHz	100KHz	300KHz
Working temperature	-20°C~70°C	-10°C~70°C	-20°C~70°C
Degree of Protection	IP65	IP55	IP65
Output signal	A; A-; B; B-; 0; 0-; 0V; +V; GND	A; A-; B; B-; Z; Z-; 0V; +V; GND	A; A-; B; B-; 0; 0-; 0V; +V; GND

◆ Encoder machine dimension

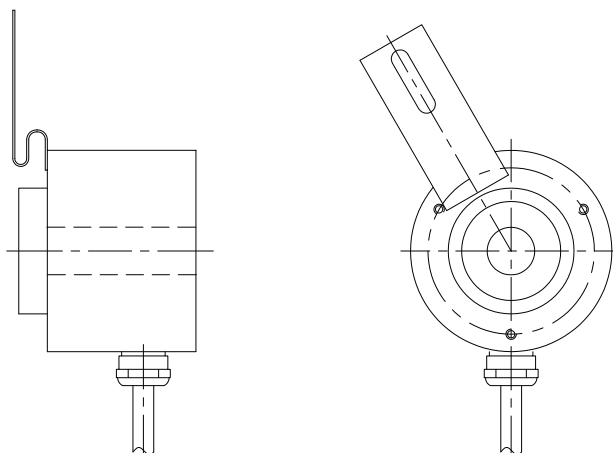

5.3 Brake

According to user requirements, BONENG motors can installed an external brake device on the motor back end cover, the brake device is a DC coil excitation disc brake, electromagnetic force generated when the DC coil is energized acts on the spring to release the brake. Brakes are designed for loss of power and meet basic safety requirements. Brake can select mounted manual release handle or release screw to achieve mechanical release. Each brake is equipped with a rectifying device because the brake coil works with direct current. The device is used to change the power frequency current(single phase or two phase)provided by the outside through a simple bridge rectifier structure to the direct current to meet the working needs of brake coil, and supply it to the brake coil. Brakes are controlled by a control system that can be installed in the motor terminal box or in a power distribution cabinet.

Brake structure principle is as follows:

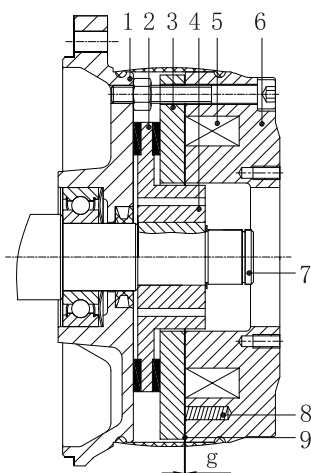

- 1、 Motor back end cover
- 2、 Brake friction disk
- 3、 Brake armature disks
- 4、 Brake splined hub
- 5、 Brake DC excitation coil
- 6、 Brake stator
- 7、 Motor shaft
- 8、 Brake thrust spring
- 9、 Brake air gap

◆ Braking fast brake (Preset normally open connects)

Using BONENG universal brake motors for applications such as hoisting gear or other applications that require brakes to minimize brake delay after motor has been powered down for immediate braking, BONENG motor to the brake configuration of the rectifier to provide users with a pair of rectifier DC circuit normally open contact, through the normally open contact of the control, you can easily and quickly achieve the rapid braking you want.

Rectifier schematic diagram is as follows:

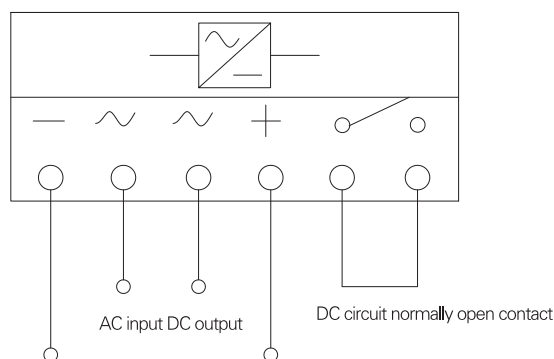

◆ Brake micro switch

Brake micro switch provides a group of normally open and a group of normally closed switch signal used to detect the working status of the brake, the micro switch can feed back a switch quantity signal by detecting the working state of the brake , By processing the feedback switch signal, the brake can be effectively prevented from starting without releasing the motor, In this way, the brake working state monitoring and more effective protection of the motor.

◆ When the motor is selected for brakes, the corresponding accessory code must be selected according to the requirement; Brakes can provide different voltage configurations to meet user needs.

◆ Brake parameters

Brake type	BN05	BN06	BN10	BN14	BN16	BN18	BN20	BN25	BN30
Brake torque (N.m)	2	4	16	60	80	150	300	600	1000
Brake power (W)	13	20	30	50	55	85	100	110	200
Rated gap (mm)	0.2	0.2	0.2	0.3	0.3	0.4	0.4	0.5	0.6
Maximum gap (mm)	0.5	0.5	0.5	0.75	0.75	1	1	1.25	1.5
AC brake voltage (AC-V)	230or400	230or400	230or400	230or400	400	400	400	400	400
DC brake voltage (DC-V)	103or180	103or180	103or180	103or180	180	180	180	180	180
Fit motor frame size	56-63	71	80-90	100-112	132	160	180	200-225	250-280
Brake actuation time (ms)	40	40	70	190	200	260	340	390	420
Slow brake releasing time (ms)	300	300	450	570	600	780	1650	2000	3000
Rapid brake releasing time (ms)	30	30	45	57	60	78	165	230	380

5.4 Motor thermal protection

Motor thermal protection refers to the temperature protection sensor or temperature detection sensor embedded in the motor stator windings or other appropriate place, so that motor will not be damaged due to overheating. Temperature sensor options are as follows:

- ◆ PTC thermistor temperature protection

Three PTC thermistors are connected in series with each resistor buried in the motor three-phase winding end and leads from the terminal box, the user can according to the actual situation connected them to the frequency converter terminal drive or the thermorelay thermal relay to achieve the motor winding overheating protection. At present, the most commonly used motor winding overheating protection is the use of PTC thermistors installed in the motor windings for protection. The winding temperature can be accurately monitored due to the lower thermal capacity of the thermistor and its excellent thermal conductivity around the foot. When the limit temperature is reached (nominal trip temperature), there is a step change in the PTC thermistor resistance. After this change is captured by the trip device, the auxiliary circuit can be disconnected. PTC thermistor itself can't tolerate high current and high voltage, otherwise it will lead to damage to the semiconductor device. PTC thermistor and trip device switching hysteresis effect is small, so you can achieve rapid restart. For heavy load start, high start frequency, large load changes, high ambient temperature or power fluctuations and other applications, we recommended that the motor use this type of protection.

- ◆ Thermal switch temperature protection

3 bimetal switches in series way to each switch are buried in the motor end of the three-phase winding and leads from the terminal box, bimetal switches provide the switch signal, the user can achieve the motor winding overheating protection based on the actual situation in the detection circuit.

- ◆ PT100 Thermistor Sensor Temperature Protection

PT100 thermistor is a high preciseness, high sensitivity sensor with better linear temperature resistance than other resistive sensors with stable performance and high reliability.

- ◆ Moisture-proof heating protection

When the motor is in a harsh environment, such as large humidity or relatively large temperature difference between day and night, the motor winding is likely to condensation phenomenon, which will bring the risk of motor burned. In this case, we advisable to configure the motor windings with moisture-proof heating belt. The motor must be in not working state when the Moisture-proof heating belt is in the working process; when the motor is down, moisture-proof heating belt must be started for the winding heating. Electrical parameters of moisture-proof heating belt are shown in the following table.

Electrical parameters of moisture-proof heating belt

Frame size	Power (W)	Voltage (V)
56-71	10	220
80-90	20	220
100-112	30	220
132-160	40	220
180-200	50	220
225-280	60	220

6 Frequency conversion applications

BONENG general-purpose fully-enclosed self-fan cooling three-phase asynchronous motors are suitable for variable speed, constant speed. The motor can be driven by the inverter with a specific load. The load torque that the motor can withstand at different frequencies is shown in the figure below:

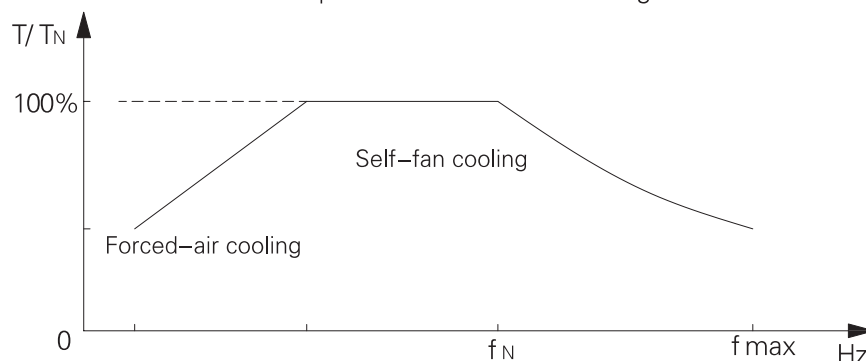

T: Output torque TN: Rated torque fN: Rated frequency fmax: Maximum frequency

When the load torque is within the allowable torque range, the motor can be cooled by the self-fan; when the load torque exceeds the allowable torque, the motor needs to be forced to cool. When the motor speed exceeds the rated speed, the noise and vibration values will increase and the bearing life will be shortened.

The maximum safe speed allowed of the motor is as follows:

Frame size	4-pole		6-pole	
	Maximum speed (r/min)	Maximum frequency (Hz)	Maximum speed (r/min)	Maximum frequency (Hz)
63	3600	120	/	/
71	3600	120	2400	120
80	3600	120	2400	120
90	3600	120	2400	120
100	3600	120	2400	120
112	3600	120	2400	120
132	2700	90	2400	120
160	2700	90	2400	120
180	2700	90	2400	120
200	2250	75	1800	90
225	2250	75	1800	90
250	2250	75	1800	90
280	2250	75	1800	90

7 MH/MP motor type Designation

MH132S4B55 H C 3-A 0 N 0 0-1 1 1

Cable entry location

1/2/3/4

Terminal box location

1/2/3/4

Mounting position

1/2/3/4/5/6

Degree of protection

0= standard configuration (IP55/F) 1= with rain cover J=with metal joint K= with metal joint and rain cover
4= IP65/with metal joint 5= IP65/with metal joint and rain cover

Thermal protection and heating protection

0= no winding protection 1= thermistor 2= thermostat 3= PT100 temperature sensor
4= heating belt 5= thermistor and heating belt 6= thermostat and heating belt
7= PT100 temperature sensor and heating belt

Brake	N=no brake A=220-240VAC brake D=220-240VAC brake with handle B=380-415VAC brake E=380-415VAC brake with handle R=220-240VAC double brake with handle S=380-415VAC double brake with handle	Brake	N=no brake B=380-415VAC brake E=380-415VAC brake with handle S=380-415VAC double brake with handle
--------------	--	--------------	---

Encoder

0= no encoder 3= economic HTL encoder (1024P) 4= high-performance TTL encoder(1024P)
1= high-performance HTL encoder (1024P) 2= standard encoder accessories

Cooling method

A= self-fan cooling
F= forced-fan cooling (it must be chosen with encoder; otherwise, it is not advised to choose)

Frequency/voltage	1=50Hz 220V△/380VY 2=50Hz 230V△/400VY 8=60Hz 460VY C=60Hz 480VY E=60Hz 220V△/380VY	Frequency/voltage	3=50Hz 380V△/660VY 4=50Hz 400V△/690VY 5=60Hz 440V△ 6=60Hz 460V△ B=50Hz 415V△ D=60Hz 480V△ F=60Hz 380V△
--------------------------	--	--------------------------	--

Frame material

L=cast-aluminum(frame size≤100) C=cast-iron frame

Type of construction	H=B3 foot-mounted F=B5 flange-mounted S=B14B flange-mounted	Type of construction	H=B3 foot-mounted F=B5 flange-mounted S=B14B flange-mounted (frame size≤132)
-----------------------------	---	-----------------------------	--

Power(kW)	MH=IE2 three-phase asynchronous motor MP=IE3 three-phase asynchronous motor		Power(kW)	MH=IE2 three-phase asynchronous motor MP=IE3 three-phase asynchronous motor	
	4 Poles	6 Poles		4 Poles	6 Poles
0.12	MH063M4A12... MP063M4A12...	/	4	MH112L4B40... MP112L4B40...	MH132M6B40... MP132M6B40...
0.18	MH063M4A18... MP063M4A18...	MH071M6A18... MP071M6A18...	5.5	MH132S4B55... MP132M4B55...	MH132M6B55... MP132L6B55...
0.25	MH071M4A25... MP071M4A25...	MH071M6A25... MP071M6A25...	7.5	MH132M4B75... MP132L4B75...	MH160S6B75... MP160S6B75...
0.37	MH071M4A37... MP071M4A37...	MH080M6A37... MP080M6A37...	11	MH160S4C11... MP160M4C11...	MH160M6C11... MP160M6C11...
0.55	MH080M4A55... MP080M4A55...	MH080M6A55... MP080M6A55...	15	MH160M4C15... MP160L4C15...	MH180M6C15... MP180M6C15...
0.75	MH080M4A75... MP080M4A75...	MH090S6A75... MP090S6A75...	18.5	MH180M4C18... MP180M4C18...	MH200M6C18... MP200M6C18...
1.1	MH090S4B11... MP090S4B11...	MH090S6B11... MP090M6B11...	22	MH180L4C22... MP180L4C22...	MH200M6C22... MP200M6C22...
1.5	MH090S4B15... MP090M4B15...	MH100M6B15... MP100M6B15...	30	MH200M4C30... MP200M4C30...	MH225M6C30... MP225M6C30...
2.2	MH100M4B22... MP100M4B22...	MH112M6B22... MP112M6B22...	37	MH225M4C37... MP225M4C37...	MH250M6C37... MP250M6C37...
3	MH100M4B30... MP100M4B30...	MH132S6B30... MP132S6B30...	45	MH225M4C45... MP225M4C45...	MH280S6C45... MP280S6C45...
/	/	/	55	MH250M4C55... MP250M4C55...	MH280M6C55... MP280M6C55...
/	/	/	75	MH280S4C75... MP280S4C75...	/
/	/	/	90	MH280M4C90... MP280M4C90...	/

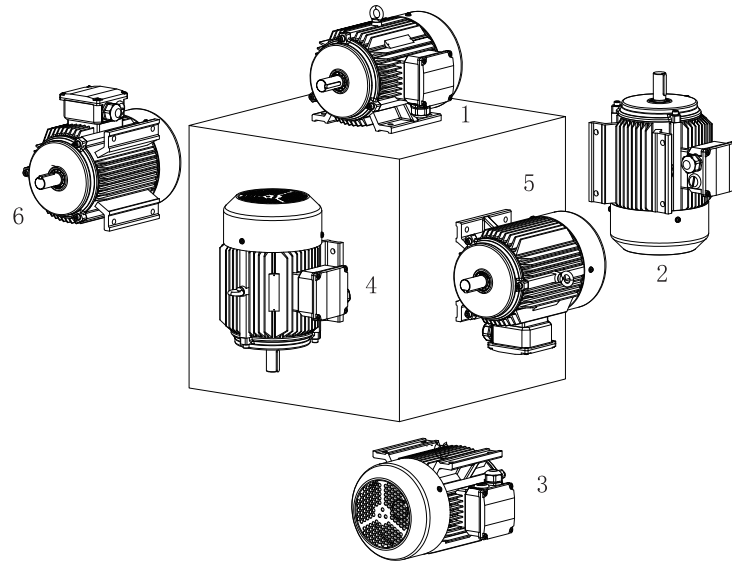
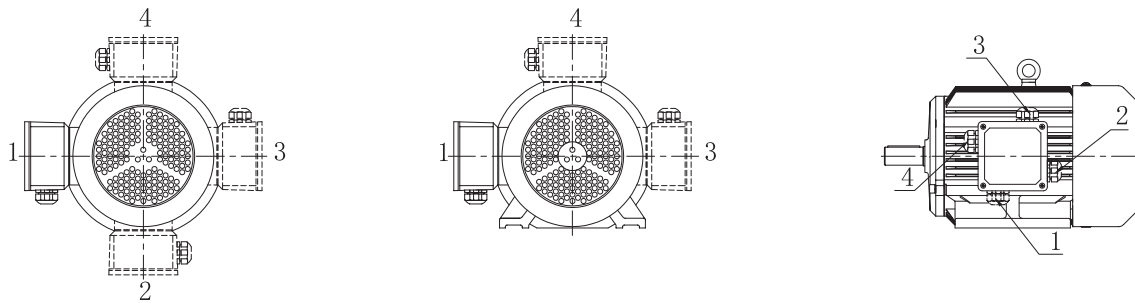
Motor mounting position:**Motor terminal box and cable entry location(View Angle: motor tail):**

Standard color of motor  (RAL5015)

8 MH motor selection technical data (efficiency IE2)

50Hz 380V 4P-1500r/min S1

Frame size	P _N (kW)	U _N (V)	F _N (Hz)	Conn.	n _N (r/min)	T _N (N.m)	IE-CL	η (%)	COS Φ	I _N (A)	T _{st} /T _N	T _{max} /T _N	I _{st} /I _N	LwdB (A)	J (kg.m ²)
063M	0.12	220/380	50	△/Y	1325	0.9	IE2	59.1	0.73	0.75/0.45	2.1	2.4	3.1	53	0.00034
063M	0.18	220/380	50	△/Y	1320	1.3	IE2	64.7	0.75	1/0.6	2.1	2.3	3.1	53	0.00041
071M	0.25	220/380	50	△/Y	1350	1.8	IE2	68.5	0.75	1.3/0.75	2.4	2.4	3.6	53	0.00062
071M	0.37	220/380	50	△/Y	1340	2.6	IE2	72.7	0.76	1.8/1.1	2.4	2.5	3.6	53	0.00074
080M	0.55	220/380	50	△/Y	1405	3.7	IE2	77.1	0.77	2.5/1.4	2.2	2.4	4.6	56	0.0017
080M	0.75	220/380	50	△/Y	1410	5.1	IE2	79.6	0.78	3.2/1.9	2.4	2.4	4.9	56	0.00206
090S	1.1	220/380	50	△/Y	1415	7.4	IE2	81.4	0.78	4.6/2.7	2.6	2.4	5.6	59	0.00318
090S	1.5	220/380	50	△/Y	1415	10.1	IE2	82.8	0.79	6/3.5	2.7	2.4	5.7	59	0.00395
100M	2.2	220/380	50	△/Y	1440	14.6	IE2	84.3	0.82	8.4/4.9	2.4	2.7	6.2	64	0.00846
100M	3	220/380	50	△/Y	1440	19.9	IE2	85.5	0.83	11.2/6.5	2.6	2.7	6.4	64	0.0102
112L	4	380/660	50	△/Y	1440	26.5	IE2	86.6	0.83	8.5/4.9	2.4	2.7	6.1	65	0.014
132S	5.5	380/660	50	△/Y	1450	36.2	IE2	87.7	0.83	11.5/6.7	2.3	2.7	6.6	71	0.029
132M	7.5	380/660	50	△/Y	1450	49.4	IE2	88.7	0.83	15.5/8.9	2.5	2.6	6.9	71	0.0374
160S	11	380/660	50	△/Y	1460	72.0	IE2	89.8	0.84	22.2/12.8	2.2	2.6	6.4	73	0.0878
160M	15	380/660	50	△/Y	1455	98.5	IE2	90.6	0.84	30/17.3	2.1	2.4	6.3	73	0.115
180M	18.5	380/660	50	△/Y	1465	120.6	IE2	91.2	0.85	36.3/21	2.3	2.9	6.7	76	0.164
180L	22	380/660	50	△/Y	1465	143.4	IE2	91.6	0.85	43/24.8	2.4	2.9	6.8	76	0.192
200M	30	380/660	50	△/Y	1470	194.9	IE2	92.3	0.86	57.5/33.5	2.4	2.8	6.6	76	0.303
225M	37	380/660	50	△/Y	1480	238.8	IE2	92.7	0.87	70/40.5	2.4	2.7	6.9	78	0.517
225M	45	380/660	50	△/Y	1480	290.4	IE2	93.1	0.87	84.5/49	2.4	2.6	6.8	78	0.609
250M	55	380/660	50	△/Y	1480	354.9	IE2	93.5	0.87	103/59.5	2.4	2.7	6.7	79	0.758
280S	75	380/660	50	△/Y	1485	482.3	IE2	94	0.88	138/80	2.5	2.7	6.7	80	1.397
280M	90	380/660	50	△/Y	1485	578.8	IE2	94.2	0.88	165/95.5	2.6	2.7	6.8	80	1.658

50Hz 400V 4P-1500r/min S1

Frame size	P _N (kW)	U _N (V)	F _N (Hz)	Conn.	n _N (r/min)	T _N (N.m)	IE-CL	η (%)	COS Φ	I _N (A)	T _{st} /T _N	T _{max} /T _N	I _{st} /I _N	LwdB (A)	J (kg.m ²)
063M	0.12	230/400	50	△/Y	1345	0.9	IE2	59.1	0.7	0.75/0.45	2.3	2.6	3.3	53	0.00034
063M	0.18	230/400	50	△/Y	1345	1.3	IE2	64.7	0.71	1/0.6	2.3	2.6	3.3	53	0.00041
071M	0.25	230/400	50	△/Y	1365	1.7	IE2	68.5	0.71	1.3/0.75	2.8	2.8	3.9	53	0.00062
071M	0.37	230/400	50	△/Y	1360	2.6	IE2	72.7	0.74	1.8/1.1	2.8	2.7	3.9	53	0.00074
080M	0.55	230/400	50	△/Y	1415	3.7	IE2	77.1	0.75	2.5/1.4	2.6	2.7	5.0	56	0.0017
080M	0.75	230/400	50	△/Y	1420	5.0	IE2	79.6	0.76	3.2/1.9	2.8	2.7	5.4	56	0.00206
090S	1.1	230/400	50	△/Y	1425	7.4	IE2	81.4	0.76	4.5/2.6	3.1	2.8	6.2	59	0.00318
090S	1.5	230/400	50	△/Y	1425	10.1	IE2	82.8	0.77	5.9/3.4	3.2	2.7	6.3	59	0.00395
100M	2.2	230/400	50	△/Y	1445	14.5	IE2	84.3	0.79	8.3/4.8	2.8	3.1	6.8	64	0.00846
100M	3	230/400	50	△/Y	1445	19.8	IE2	85.5	0.8	11/6.4	3.0	3.1	7.1	64	0.0102
112L	4	400/690	50	△/Y	1445	26.4	IE2	86.6	0.8	8.4/4.8	2.8	3.0	6.8	65	0.014
132S	5.5	400/690	50	△/Y	1455	36.1	IE2	87.7	0.81	11.2/6.5	2.7	3.0	7.4	71	0.029
132M	7.5	400/690	50	△/Y	1455	49.2	IE2	88.7	0.82	14.9/8.6	2.9	3.0	7.8	71	0.0374
160S	11	400/690	50	△/Y	1460	72.0	IE2	89.8	0.82	21.6/12.5	2.6	2.9	7.2	73	0.0878
160M	15	400/690	50	△/Y	1460	98.1	IE2	90.6	0.83	29/17	2.4	2.7	7.2	73	0.115
180M	18.5	400/690	50	△/Y	1470	120.2	IE2	91.2	0.84	35/20.5	2.7	3.3	7.5	76	0.164
180L	22	400/690	50	△/Y	1470	142.9	IE2	91.6	0.84	41.5/24	2.8	3.3	7.6	76	0.192
200M	30	400/690	50	△/Y	1470	194.9	IE2	92.3	0.85	55.5/32	2.8	3.2	7.4	76	0.303
225M	37	400/690	50	△/Y	1480	238.8	IE2	92.7	0.85	68/39.5	2.8	3.1	7.8	78	0.517
225M	45	400/690	50	△/Y	1480	290.4	IE2	93.1	0.86	81.5/47	2.8	3.0	7.7	78	0.609
250M	55	400/690	50	△/Y	1480	354.9	IE2	93.5	0.85	100/58	2.8	3.1	7.6	79	0.758
280S	75	400/690	50	△/Y	1485	482.3	IE2	94	0.86	134/77.5	2.9	3.0	7.5	80	1.397
280M	90	400/690	50	△/Y	1485	578.8	IE2	94.2	0.87	159/92	3.0	3.0	7.5	80	1.658

50Hz 380V 6P-1000r/min S1

Frame size	P _N (kW)	U _N (V)	F _N (Hz)	Conn.	n _N (r/min)	T _N (N.m)	IE-CL	η(%)	COS Φ	I _N (A)	T _{st} /T _N	T _{max} /T _N	I _{st} /I _N	L _w dB (A)	J (kg.m ²)
071M	0.18	220/380	50	△/Y	870	2.0	IE2	56.6	0.69	1.3/0.75	2.0	2.3	2.7	51	0.001
071M	0.25	220/380	50	△/Y	870	2.7	IE2	61.6	0.69	1.6/0.9	2.1	2.3	2.8	51	0.00115
080M	0.37	220/380	50	△/Y	930	3.8	IE2	67.6	0.73	2.1/1.2	2.0	2.3	3.7	54	0.00212
080M	0.55	220/380	50	△/Y	925	5.7	IE2	73.1	0.75	2.8/1.6	2.0	2.2	3.7	54	0.00258
090S	0.75	220/380	50	△/Y	935	7.7	IE2	75.9	0.74	3.6/2.1	1.9	2.2	3.9	57	0.00358
090S	1.1	220/380	50	△/Y	935	11.2	IE2	78.1	0.75	5.0/2.9	2.1	2.2	4.1	57	0.00478
100M	1.5	220/380	50	△/Y	940	15.2	IE2	79.8	0.75	6.6/3.8	2.2	2.3	4.5	61	0.0097
112M	2.2	220/380	50	△/Y	940	22.4	IE2	81.8	0.75	9.5/5.5	2.3	2.3	4.8	65	0.0158
132S	3	220/380	50	△/Y	965	29.7	IE2	83.3	0.76	12.5/7.3	2.4	2.7	5.8	69	0.0299
132M	4	380/660	50	△/Y	965	39.6	IE2	84.6	0.77	9.4/5.4	2.6	2.8	6.2	69	0.0389
132M	5.5	380/660	50	△/Y	965	54.4	IE2	86	0.79	12.4/7.2	2.6	2.7	6.3	69	0.0522
160S	7.5	380/660	50	△/Y	960	74.6	IE2	87.2	0.79	16.6/9.6	2.1	2.3	5.2	73	0.094
160M	11	380/660	50	△/Y	960	109.4	IE2	88.7	0.8	23.6/13.7	2.1	2.3	5.3	73	0.135
180M	15	380/660	50	△/Y	975	146.9	IE2	89.7	0.82	31/18	2.2	2.7	6.0	73	0.238
200M	18.5	380/660	50	△/Y	975	181.2	IE2	90.4	0.82	38/22	2.4	2.8	6.3	73	0.375
200M	22	380/660	50	△/Y	975	215.5	IE2	90.9	0.82	45/26	2.4	2.7	6.3	73	0.421
225M	30	380/660	50	△/Y	980	292.3	IE2	91.7	0.83	60/35	2.1	2.2	5.9	74	0.595
250M	37	380/660	50	△/Y	980	360.6	IE2	92.2	0.84	73/42	2.4	3.2	6.8	76	1.01
280S	45	380/660	50	△/Y	985	436.3	IE2	92.7	0.85	87/50.5	2.3	2.9	6.7	78	1.678
280M	55	380/660	50	△/Y	985	533.2	IE2	93.1	0.86	105/60.5	2.4	2.9	6.7	78	2.012

50Hz 400V 6P-1000r/min S1

Frame size	P _N (kW)	U _N (V)	F _N (Hz)	Conn.	n _N (r/min)	T _N (N.m)	IE-CL	η(%)	COS Φ	I _N (A)	T _{st} /T _N	T _{max} /T _N	I _{st} /I _N	L _w dB (A)	J (kg.m ²)
071M	0.18	230/400	50	△/Y	880	2.0	IE2	56.6	0.65	1.3/0.75	2.3	2.6	2.9	51	0.001
071M	0.25	230/400	50	△/Y	880	2.7	IE2	61.6	0.65	1.6/0.95	2.4	2.6	3.0	51	0.00115
080M	0.37	230/400	50	△/Y	935	3.8	IE2	67.6	0.69	2.1/1.2	2.3	2.6	4.0	54	0.00212
080M	0.55	230/400	50	△/Y	935	5.6	IE2	73.1	0.71	2.8/1.6	2.3	2.1	4.0	54	0.00258
090S	0.75	230/400	50	△/Y	940	7.6	IE2	75.9	0.7	3.6/2.1	2.3	2.5	4.3	57	0.00358
090S	1.1	230/400	50	△/Y	940	11.2	IE2	78.1	0.7	5.1/2.9	2.5	2.6	5.6	57	0.00478
100M	1.5	230/400	50	△/Y	945	15.2	IE2	79.8	0.72	6.5/3.8	2.6	2.6	5.0	61	0.0097
112M	2.2	230/400	50	△/Y	945	22.2	IE2	81.8	0.72	9.4/5.4	2.8	2.6	5.3	65	0.0158
132S	3	230/400	50	△/Y	965	29.7	IE2	83.3	0.73	12.5/7.2	2.9	3.1	6.3	69	0.0299
132M	4	400/690	50	△/Y	965	39.6	IE2	84.6	0.73	9.4/5.5	3.0	3.2	6.7	69	0.0389
132M	5.5	400/690	50	△/Y	965	54.4	IE2	86	0.75	12.5/7.5	3.1	3.1	7.0	69	0.0522
160S	7.5	400/690	50	△/Y	965	74.2	IE2	87.2	0.77	16.2/9.4	2.5	2.7	5.8	73	0.094
160M	11	400/690	50	△/Y	965	108.9	IE2	88.7	0.78	23/13.5	2.6	2.6	6.0	73	0.135
180M	15	400/690	50	△/Y	975	146.9	IE2	89.7	0.79	31/18	2.6	3.1	6.7	73	0.238
200M	18.5	400/690	50	△/Y	980	180.3	IE2	90.4	0.79	37.5/22	2.8	3.1	7.0	73	0.375
200M	22	400/690	50	△/Y	980	214.4	IE2	90.9	0.8	44/25.5	2.9	3.1	7.0	73	0.421
225M	30	400/690	50	△/Y	985	290.9	IE2	91.7	0.81	58.5/34	2.5	2.6	6.6	74	0.595
250M	37	400/690	50	△/Y	985	358.7	IE2	92.2	0.82	71/41	2.8	3.6	7.6	76	1.01
280S	45	400/690	50	△/Y	985	436.3	IE2	92.7	0.83	84.5/49	2.7	3.3	7.5	78	1.678
280M	55	400/690	50	△/Y	985	533.2	IE2	93.1	0.84	105/59	2.8	3.2	7.5	78	2.012

MH motor selection technical data(continue)

60Hz 440V 4P-1800r/min S1

Frame size	PN (kW)	UN (V)	FN (Hz)	Conn.	IN (r/min)	TN (N.m)	IE-CL	η (%)	COS Φ	IN (A)	Tst/TN	Tmax/TN	Ist/IN	LwdB (A)	J (kg.m ²)
063M	0.12	440	60	Y	1665	0.7	IE2	64	0.67	0.4	2.6	3.1	3.9	53	0.00034
063M	0.18	440	60	Y	1660	1.0	IE2	68	0.68	0.5	2.6	3.0	3.9	53	0.00041
071M	0.25	440	60	Y	1680	1.4	IE2	70	0.69	0.7	3.0	3.1	4.6	53	0.00062
071M	0.37	440	60	Y	1675	2.1	IE2	72	0.72	0.95	3.0	3.0	4.6	53	0.00074
080M	0.55	440	60	Y	1725	3.0	IE2	80	0.74	1.3	2.6	2.9	5.7	56	0.0017
080M	0.75	440	60	Y	1725	4.2	IE2	82.5	0.75	1.6	2.8	2.9	6.1	56	0.00206
090S	1.1	440	60	Y	1730	6.1	IE2	84	0.76	2.3	3.0	2.9	6.8	59	0.00318
090S	1.5	440	60	Y	1730	8.3	IE2	84	0.77	3.1	3.1	2.8	7.0	59	0.00395
100M	2.2	440	60	Y	1750	12.0	IE2	87.5	0.8	4.2	2.6	3.2	7.4	64	0.00846
100M	3	440	60	Y	1750	16.4	IE2	87.5	0.81	5.6	2.8	3.2	7.6	64	0.0102
112L	4	440	60	Δ	1745	21.9	IE2	87.5	0.81	7.4	2.6	3.1	7.2	65	0.014
132S	5.5	440	60	Δ	1755	29.9	IE2	89.5	0.82	9.9	2.5	3.1	7.8	71	0.029
132M	7.5	440	60	Δ	1760	40.7	IE2	89.5	0.82	13.3	2.6	3.1	8.1	71	0.0374
160S	11	440	60	Δ	1765	59.5	IE2	91	0.82	19.4	2.3	2.9	7.4	73	0.0878
160M	15	440	60	Δ	1760	81.4	IE2	91	0.83	26.1	2.2	2.7	7.2	73	0.115
180M	18.5	440	60	Δ	1770	99.8	IE2	92.4	0.85	31	2.5	3.3	7.7	76	0.164
180L	22	440	60	Δ	1770	118.7	IE2	92.4	0.85	37	2.6	3.3	7.9	76	0.192
200M	30	440	60	Δ	1775	161.4	IE2	93	0.86	49.5	2.7	3.2	7.6	76	0.303
225M	37	440	60	Δ	1780	198.5	IE2	93	0.86	61	2.6	3.1	8.0	78	0.517
225M	45	440	60	Δ	1780	241.4	IE2	93.6	0.87	73	2.6	3.0	7.9	78	0.609
250M	55	440	60	Δ	1780	295.1	IE2	94.1	0.86	89.5	2.6	3.1	7.8	79	0.758
280S	75	440	60	Δ	1785	401.3	IE2	94.5	0.87	120	2.8	3.0	7.9	80	1.397
280M	90	440	60	Δ	1785	481.5	IE2	94.5	0.88	143	2.9	3.0	8.0	80	1.658

60Hz 460V 4P-1800r/min S1

Frame size	PN (kW)	UN (V)	FN (Hz)	Conn.	IN (r/min)	TN (N.m)	IE-CL	η (%)	COS Φ	IN (A)	Tst/TN	Tmax/TN	Ist/IN	LwdB (A)	J (kg.m ²)
063M	0.12	460	60	Y	1675	0.7	IE2	64	0.64	0.4	2.9	3.4	4.0	53	0.00034
063M	0.18	460	60	Y	1675	1.0	IE2	68	0.65	0.5	2.9	3.3	4.1	53	0.00041
071M	0.25	460	60	Y	1690	1.4	IE2	70	0.66	0.7	3.4	3.5	4.8	53	0.00062
071M	0.37	460	60	Y	1685	2.1	IE2	72	0.68	0.95	3.4	3.3	4.9	53	0.00074
080M	0.55	460	60	Y	1730	3.0	IE2	80	0.71	1.3	3.0	3.2	6.2	56	0.0017
080M	0.75	460	60	Y	1730	4.1	IE2	82.5	0.72	1.6	3.3	3.2	6.5	56	0.00206
090S	1.1	460	60	Y	1735	6.1	IE2	84	0.73	2.3	3.5	3.2	7.4	59	0.00318
090S	1.5	460	60	Y	1735	8.3	IE2	84	0.74	3.1	3.6	3.1	7.6	59	0.00395
100M	2.2	460	60	Y	1755	12.0	IE2	87.5	0.77	4.1	3.0	3.6	8.0	64	0.00846
100M	3	460	60	Y	1755	16.3	IE2	87.5	0.78	5.6	3.3	3.6	8.3	64	0.0102
112L	4	460	60	Δ	1750	21.8	IE2	87.5	0.79	7.3	3.0	3.5	7.9	65	0.014
132S	5.5	460	60	Δ	1760	29.8	IE2	89.5	0.8	9.7	2.9	3.4	8.5	71	0.029
132M	7.5	460	60	Δ	1760	40.7	IE2	89.5	0.81	13	3.1	3.4	9.0	71	0.0374
160S	11	460	60	Δ	1765	59.5	IE2	91	0.81	18.8	2.7	3.3	8.2	73	0.0878
160M	15	460	60	Δ	1765	81.2	IE2	91	0.82	25.5	2.6	3.0	8.0	73	0.115
180M	18.5	460	60	Δ	1775	99.5	IE2	92.4	0.82	31	2.9	3.7	8.4	76	0.164
180L	22	460	60	Δ	1775	118.4	IE2	92.4	0.82	37	2.9	3.7	8.6	76	0.192
200M	30	460	60	Δ	1775	161.4	IE2	93	0.84	48.5	3.0	3.6	8.4	76	0.303
225M	37	460	60	Δ	1780	198.5	IE2	93	0.85	59	3.0	3.4	8.9	78	0.517
225M	45	460	60	Δ	1780	241.4	IE2	93.6	0.85	71	3.0	3.2	8.7	78	0.609
250M	55	460	60	Δ	1785	294.3	IE2	94.1	0.85	86.5	3.0	3.4	8.7	79	0.758
280S	75	460	60	Δ	1785	401.3	IE2	94.5	0.86	116	3.2	3.3	8.7	80	1.397
280M	90	460	60	Δ	1785	481.5	IE2	94.5	0.87	138	3.3	3.3	8.8	80	1.658

60Hz 440V 6P-1200r/min S1

Frame size	P _N (kW)	U _N (V)	F _N (Hz)	Conn.	n _N (r/min)	T _N (N.m)	IE-CL	η (%)	COS Φ	I _N (A)	T _{st} /T _N	T _{max} /T _N	I _{st} /I _N	L _w dB (A)	J (kg.m ²)
071M	0.18	440	60	Y	1100	1.6	IE2	55	0.62	0.7	2.5	2.9	3.4	51	0.001
071M	0.25	440	60	Y	1100	2.2	IE2	59.5	0.63	0.9	2.6	3.0	3.5	51	0.00115
080M	0.37	440	60	Y	1145	3.1	IE2	64	0.68	1.1	2.4	2.9	4.6	54	0.00212
080M	0.55	440	60	Y	1140	4.6	IE2	68	0.71	1.5	2.3	2.7	4.6	54	0.00258
090S	0.75	440	60	Y	1145	6.3	IE2	80	0.7	1.8	2.2	2.7	4.7	57	0.00358
090S	1.1	440	60	Y	1145	9.2	IE1	82	0.71	2.6	2.4	2.7	5.0	57	0.00478
100M	1.5	440	60	Y	1150	12.5	IE1	82.5	0.72	3.4	2.6	2.7	5.5	61	0.0097
112M	2.2	440	60	Y	1150	18.3	IE1	84.5	0.72	4.8	2.6	2.7	5.7	65	0.0158
132S	3	440	60	Y	1170	24.5	IE1	86	0.73	6.3	2.8	3.3	7.0	69	0.0299
132M	4	440	60	△	1170	32.6	IE2	87.5	0.74	8.2	2.9	3.3	7.3	69	0.0389
132M	5.5	440	60	△	1170	44.9	IE2	89.5	0.75	10.9	2.9	3.2	7.5	69	0.0522
160S	7.5	440	60	△	1165	61.5	IE2	89.5	0.78	14.2	2.3	2.7	6.0	73	0.094
160M	11	440	60	△	1165	90.2	IE2	90.2	0.79	20.3	2.3	2.6	6.2	73	0.135
180M	15	440	60	△	1180	121.4	IE2	90.2	0.8	27.5	2.4	3.1	6.9	73	0.238
200M	18.5	440	60	△	1180	149.7	IE2	91.7	0.8	33.5	2.7	3.2	7.2	73	0.375
200M	22	440	60	△	1180	178.1	IE2	91.7	0.8	39.5	2.8	3.1	7.3	73	0.421
225M	30	440	60	△	1185	241.8	IE2	93	0.82	52	2.3	2.5	6.8	74	0.595
250M	37	440	60	△	1185	298.2	IE2	93	0.82	64	2.7	3.6	7.9	76	1.01
280S	45	440	60	△	1185	362.7	IE2	93.6	0.83	76.5	2.6	3.3	7.8	78	1.678
280M	55	440	60	△	1185	443.2	IE2	93.6	0.84	92	2.6	3.3	7.8	78	2.012

60Hz 460V 6P-1200r/min S1

Frame size	P _N (kW)	U _N (V)	F _N (Hz)	Conn.	n _N (r/min)	T _N (N.m)	IE-CL	η (%)	COS Φ	I _N (A)	T _{st} /T _N	T _{max} /T _N	I _{st} /I _N	L _w dB (A)	J (kg.m ²)
071M	0.18	460	60	Y	1105	1.6	IE2	55	0.59	0.7	2.8	3.3	3.5	51	0.001
071M	0.25	460	60	Y	1105	2.2	IE2	59.5	0.59	0.9	3.0	3.3	3.6	51	0.00115
080M	0.37	460	60	Y	1150	3.1	IE2	64	0.65	1.1	2.7	3.2	4.9	54	0.00212
080M	0.55	460	60	Y	1145	4.6	IE2	68	0.67	1.5	2.7	3.0	4.9	54	0.00258
090S	0.75	460	60	Y	1150	6.2	IE2	80	0.67	1.8	2.6	3.0	5.1	57	0.00358
090S	1.1	460	60	Y	1150	9.1	IE1	82	0.67	2.6	2.9	3.1	5.4	57	0.00478
100M	1.5	460	60	Y	1155	12.4	IE1	82.5	0.68	3.4	3.0	3.1	6.0	61	0.0097
112M	2.2	460	60	Y	1155	18.2	IE1	84.5	0.69	4.8	3.1	3.1	6.2	65	0.0158
132S	3	460	60	Y	1170	24.5	IE1	86	0.7	6.2	3.2	3.6	7.4	69	0.0299
132M	4	460	60	△	1170	32.6	IE2	87.5	0.71	8.1	3.4	3.7	7.9	69	0.0389
132M	5.5	460	60	△	1170	44.9	IE2	89.5	0.73	10.7	3.4	3.6	7.1	69	0.0522
160S	7.5	460	60	△	1170	61.2	IE2	89.5	0.75	14.1	2.7	3.0	6.6	73	0.094
160M	11	460	60	△	1170	89.8	IE2	90.2	0.77	20	2.8	3.0	6.8	73	0.135
180M	15	460	60	△	1180	121.4	IE2	90.2	0.78	26.8	2.8	3.5	7.5	73	0.238
200M	18.5	460	60	△	1180	149.7	IE2	91.7	0.78	33	3.1	3.5	7.9	73	0.375
200M	22	460	60	△	1180	178.1	IE2	91.7	0.78	39	3.2	3.5	8.0	73	0.421
225M	30	460	60	△	1185	241.8	IE2	93	0.81	50	2.7	2.8	7.5	74	0.595
250M	37	460	60	△	1185	298.2	IE2	93	0.81	62	3.1	4.0	8.6	76	1.01
280S	45	460	60	△	1190	361.1	IE2	93.6	0.82	74	3.0	3.7	8.5	78	1.678
280M	55	460	60	△	1190	441.4	IE2	93.6	0.83	89	3.0	3.6	8.5	78	2.012

9 MP motor selection technical data (efficiency IE3)

50Hz 380V 4P-1500r/min S1

Frame size	P _N (kW)	U _N (V)	F _N (Hz)	Conn.	n _N (r/min)	T _N (N.m)	IE-CL	η (%)	COS Φ	I _N (A)	T _{st} /T _N	T _{max} /T _N	I _{st} /I _N	LwdB (A)	J (kg.m ²)
056M	0.09	220/380	50	△/Y	1330	0.65	-	59.1	0.73	0.55/0.35	2.1	2.4	3.1	53	0.0003
063M	0.12	220/380	50	△/Y	1325	0.9	IE3	64.8	0.73	0.7/0.4	2.1	2.4	3.1	53	0.00034
063M	0.18	220/380	50	△/Y	1340	1.3	IE3	69.9	0.73	0.95/0.55	2.2	2.5	3.4	53	0.00051
071M	0.25	220/380	50	△/Y	1365	1.7	IE3	73.5	0.74	1.3/0.75	2.5	2.6	3.9	53	0.00074
071M	0.37	220/380	50	△/Y	1375	2.6	IE3	77.3	0.75	1.7/1.0	2.7	2.7	4.2	53	0.00099
080M	0.55	220/380	50	△/Y	1420	3.7	IE3	80.8	0.76	2.4/1.4	2.5	2.7	5.3	56	0.0019
080M	0.75	220/380	50	△/Y	1420	5.0	IE3	82.5	0.78	3.1/1.8	2.4	2.5	5.3	56	0.00249
090S	1.1	220/380	50	△/Y	1425	7.4	IE3	84.1	0.78	4.4/2.6	2.5	2.5	5.9	59	0.00351
090M	1.5	220/380	50	△/Y	1425	10.1	IE3	85.3	0.78	5.8/3.5	2.7	2.5	6.2	59	0.00442
100M	2.2	220/380	50	△/Y	1450	14.5	IE3	86.7	0.82	8.3/4.8	2.6	3.0	6.8	64	0.00926
100M	3	220/380	50	△/Y	1450	19.8	IE3	87.7	0.82	11/6.5	2.8	3.0	7.1	64	0.0113
112L	4	380/660	50	△/Y	1450	26.3	IE3	88.6	0.82	8.4/4.9	2.1	2.6	6.2	65	0.0143
132M	5.5	380/660	50	△/Y	1460	36.0	IE3	89.6	0.84	11.5/6.6	2.0	2.5	6.7	71	0.0307
132L	7.5	380/660	50	△/Y	1460	49.1	IE3	90.4	0.85	15/8.7	2.0	2.4	6.6	71	0.0382
160M	11	380/660	50	△/Y	1470	71.5	IE3	91.4	0.84	21.8/12.6	2.2	3.1	7.0	73	0.095
160L	15	380/660	50	△/Y	1470	97.4	IE3	92.1	0.85	29.5/17	2.3	3.1	7.0	73	0.12
180M	18.5	380/660	50	△/Y	1475	119.8	IE3	92.6	0.86	35.5/20.5	2.1	3.0	7.1	76	0.169
180L	22	380/660	50	△/Y	1475	142.4	IE3	93	0.86	42/24.5	2.3	3.0	7.3	76	0.195
200M	30	380/660	50	△/Y	1475	194.2	IE3	93.6	0.85	58/33.5	2.4	2.7	6.2	76	0.317
225M	37	380/660	50	△/Y	1480	238.8	IE3	93.9	0.86	70/40.5	2.5	2.7	6.9	78	0.555
225M	45	380/660	50	△/Y	1480	290.4	IE3	94.2	0.86	85/49	2.4	2.5	6.5	78	0.621
250M	55	380/660	50	△/Y	1485	353.7	IE3	94.6	0.86	103/60	2.4	2.7	6.8	79	0.839
280S	75	380/660	50	△/Y	1490	480.7	IE3	95	0.87	139/80	2.4	2.7	6.4	80	1.592
280M	90	380/660	50	△/Y	1490	576.8	IE3	95.2	0.87	166/96	2.5	2.8	6.7	80	1.887

50Hz 400V 4P-1500r/min S1

Frame size	P _N (kW)	U _N (V)	F _N (Hz)	Conn.	n _N (r/min)	T _N (N.m)	IE-CL	η (%)	COS Φ	I _N (A)	T _{st} /T _N	T _{max} /T _N	I _{st} /I _N	LwdB (A)	J (kg.m ²)
056M	0.09	230/400	50	△/Y	1345	0.65	-	59.1	0.7	0.55/0.35	2.3	2.7	3.3	53	0.0003
063M	0.12	230/400	50	△/Y	1345	0.9	IE3	64.8	0.69	0.7/0.4	2.3	2.6	3.3	53	0.00034
063M	0.18	230/400	50	△/Y	1360	1.3	IE3	69.9	0.71	0.95/0.55	2.5	2.8	3.6	53	0.00051
071M	0.25	230/400	50	△/Y	1380	1.7	IE3	73.5	0.71	1.2/0.7	2.9	3.0	4.3	53	0.00074
071M	0.37	230/400	50	△/Y	1385	2.6	IE3	77.3	0.72	1.7/1.0	3.2	3.0	4.6	53	0.00099
080M	0.55	230/400	50	△/Y	1430	3.7	IE3	80.8	0.73	2.4/1.4	3.0	3.0	5.8	56	0.0019
080M	0.75	230/400	50	△/Y	1430	5.0	IE3	82.5	0.75	3.1/1.8	3.0	2.8	5.9	56	0.00249
090S	1.1	230/400	50	△/Y	1435	7.3	IE3	84.1	0.76	4.3/2.5	3.1	2.8	6.6	59	0.00351
090M	1.5	230/400	50	△/Y	1435	10.0	IE3	85.3	0.77	5.8/3.3	3.3	2.8	7.0	59	0.00442
100M	2.2	230/400	50	△/Y	1455	14.4	IE3	86.7	0.79	8.1/4.7	3.0	3.4	7.5	64	0.00926
100M	3	230/400	50	△/Y	1455	19.7	IE3	87.7	0.79	10.9/6.3	3.3	3.4	7.8	64	0.0113
112L	4	400/690	50	△/Y	1455	26.3	IE3	88.6	0.81	8.2/4.7	2.6	2.9	7.1	65	0.0143
132M	5.5	400/690	50	△/Y	1465	35.9	IE3	89.6	0.82	11/6.4	2.5	2.9	7.7	71	0.0307
132L	7.5	400/690	50	△/Y	1465	48.9	IE3	90.4	0.83	14.6/8.5	2.5	2.8	7.7	71	0.0382
160M	11	400/690	50	△/Y	1475	71.2	IE3	91.4	0.82	21.5/12.3	2.6	3.6	7.8	73	0.095
160L	15	400/690	50	△/Y	1475	97.1	IE3	92.1	0.83	28.5/16.5	2.6	3.5	7.8	73	0.12
180M	18.5	400/690	50	△/Y	1475	119.8	IE3	92.6	0.84	34.5/20	2.5	3.4	7.9	76	0.169
180L	22	400/690	50	△/Y	1475	142.4	IE3	93	0.84	41/23.5	2.7	3.5	8.2	76	0.195
200M	30	400/690	50	△/Y	1475	194.2	IE3	93.6	0.84	55.5/32	2.8	3.1	6.9	76	0.317
225M	37	400/690	50	△/Y	1485	237.9	IE3	93.9	0.85	67.5/39	2.9	3.1	7.7	78	0.555
225M	45	400/690	50	△/Y	1485	289.4	IE3	94.2	0.85	81.5/47	2.8	2.9	7.4	78	0.621
250M	55	400/690	50	△/Y	1485	353.7	IE3	94.6	0.85	99.5/57.5	2.8	3.1	7.7	79	0.839
280S	75	400/690	50	△/Y	1490	480.7	IE3	95	0.86	134/77	2.8	3.0	7.2	80	1.592
280M	90	400/690	50	△/Y	1490	576.8	IE3	95.2	0.86	160/92	3.0	3.1	7.5	80	1.887

50Hz 380V 6P-1000r/min S1

Frame size	P _N (kW)	U _N (V)	F _N (Hz)	Conn.	n _N (r/min)	T _N (N.m)	IE-CL	η(%)	COS Φ	I _N (A)	T _{st} /T _N	T _{max} /T _N	I _{st} /I _N	L _w dB (A)	J (kg.m ²)
071M	0.18	220/380	50	△/Y	880	2.0	IE3	63.9	0.68	1.1/0.65	2.1	2.4	2.8	51	0.00115
071M	0.25	220/380	50	△/Y	880	2.7	IE3	68.8	0.7	1.4/0.8	2.1	2.3	2.9	51	0.0013
080M	0.37	220/380	50	△/Y	935	3.8	IE3	73.5	0.73	1.9/1.1	2.0	2.4	4.0	54	0.00227
080M	0.55	220/380	50	△/Y	935	5.6	IE3	77.2	0.74	2.6/1.5	2.0	2.4	4.1	54	0.0032
090S	0.75	220/380	50	△/Y	940	7.6	IE3	78.9	0.73	3.4/2.0	1.9	2.4	4.1	57	0.00418
090M	1.1	220/380	50	△/Y	945	11.1	IE3	81	0.74	4.9/2.8	3.0	2.3	4.3	57	0.00599
100M	1.5	220/380	50	△/Y	950	15.1	IE3	82.5	0.74	6.5/3.8	2.4	2.5	5.1	61	0.0117
112M	2.2	220/380	50	△/Y	955	22.0	IE3	84.3	0.76	9.1/5.3	2.2	2.3	5.2	65	0.0171
132S	3	220/380	50	△/Y	965	29.7	IE3	85.6	0.76	12.2/7.1	2.2	2.4	5.9	69	0.0332
132M	4	380/660	50	△/Y	970	39.4	IE3	86.8	0.77	9.1/5.3	2.3	2.4	6.2	69	0.043
132L	5.5	380/660	50	△/Y	970	54.1	IE3	88	0.78	12.2/7.1	2.2	2.2	6.2	69	0.0571
160S	7.5	380/660	50	△/Y	970	73.8	IE3	89.1	0.8	16/9.3	1.9	2.7	5.3	73	0.104
160M	11	380/660	50	△/Y	970	108.3	IE3	90.3	0.8	23.2/13.4	2.1	2.7	5.6	73	0.146
180M	15	380/660	50	△/Y	980	146.2	IE3	91.2	0.82	30.5/17.7	2.2	2.8	7.0	73	0.232
200M	18.5	380/660	50	△/Y	980	180.3	IE3	91.7	0.81	38/22	2.0	2.5	5.7	73	0.374
200M	22	380/660	50	△/Y	980	214.4	IE3	92.2	0.81	45/26	2.0	2.4	5.6	73	0.417
225M	30	380/660	50	△/Y	985	290.9	IE3	92.9	0.82	60/35	2.2	2.4	6.1	74	0.625
250M	37	380/660	50	△/Y	985	358.7	IE3	93.3	0.84	72/42	2.3	2.7	6.0	76	1.063
280S	45	380/660	50	△/Y	990	434.1	IE3	93.7	0.84	87/50.5	2.2	2.7	6.3	78	1.675
280M	55	380/660	50	△/Y	990	530.6	IE3	94.1	0.85	105/61	2.2	2.6	6.3	78	2.02

50Hz 400V 6P-1000r/min S1

Frame size	P _N (kW)	U _N (V)	F _N (Hz)	Conn.	n _N (r/min)	T _N (N.m)	IE-CL	η(%)	COS Φ	I _N (A)	T _{st} /T _N	T _{max} /T _N	I _{st} /I _N	L _w dB (A)	J (kg.m ²)
071M	0.18	230/400	50	△/Y	890	1.9	IE3	63.9	0.65	1.1/0.65	2.4	2.7	3.0	51	0.00115
071M	0.25	230/400	50	△/Y	890	2.7	IE3	68.8	0.66	1.4/0.8	2.4	2.6	3.1	51	0.0013
080M	0.37	230/400	50	△/Y	940	3.8	IE3	73.5	0.69	1.9/1.1	2.4	2.7	4.3	54	0.00227
080M	0.55	230/400	50	△/Y	940	5.6	IE3	77.2	0.71	2.6/1.5	2.4	2.7	4.5	54	0.0032
090S	0.75	230/400	50	△/Y	950	7.5	IE3	78.9	0.7	3.4/2	2.3	2.7	4.6	57	0.00418
090M	1.1	230/400	50	△/Y	950	11.1	IE3	81	0.71	4.8/2.8	2.4	2.7	4.8	57	0.00599
100M	1.5	230/400	50	△/Y	955	15.0	IE3	82.5	0.71	6.4/3.7	2.9	2.9	5.6	61	0.0117
112M	2.2	230/400	50	△/Y	960	21.9	IE3	84.3	0.73	9.0/5.2	2.7	2.7	5.8	65	0.0171
132S	3	230/400	50	△/Y	970	29.5	IE3	85.6	0.73	12.1/7	2.8	2.7	6.7	69	0.0332
132M	4	400/690	50	△/Y	975	39.2	IE3	86.8	0.74	9.0/5.2	2.9	2.8	7.1	69	0.043
132L	5.5	400/690	50	△/Y	975	53.9	IE3	88	0.75	12.1/7.0	2.8	2.6	7.1	69	0.0571
160S	7.5	400/690	50	△/Y	975	73.5	IE3	89.1	0.77	15.8/9.2	2.3	3.0	5.9	73	0.104
160M	11	400/690	50	△/Y	975	107.7	IE3	90.3	0.77	22.9/13.2	2.5	3.1	6.2	73	0.146
180M	15	400/690	50	△/Y	980	146.2	IE3	91.2	0.8	29.7/17.2	2.7	3.2	7.8	73	0.232
200M	18.5	400/690	50	△/Y	985	179.4	IE3	91.7	0.8	36.5/21.1	2.4	2.9	6.4	73	0.374
200M	22	400/690	50	△/Y	985	213.3	IE3	92.2	0.8	43.5/25	2.4	2.8	6.4	73	0.417
225M	30	400/690	50	△/Y	985	290.9	IE3	92.9	0.81	58/33.5	2.6	2.7	6.9	74	0.625
250M	37	400/690	50	△/Y	985	358.7	IE3	93.3	0.82	70/40.5	2.6	3.1	6.7	76	1.063
280S	45	400/690	50	△/Y	990	434.1	IE3	93.7	0.83	84/48.5	2.6	3.0	7.1	78	1.675
280M	55	400/690	50	△/Y	990	530.6	IE3	94.1	0.84	101/58	2.6	2.9	7.1	78	2.02

MP motor selection technical data(continue)

60Hz 440V 4P-1800r/min S1

Frame size	P _N (kW)	U _N (V)	F _N (Hz)	Conn.	n _N (r/min)	T _N (N.m)	IE-CL	η(%)	COS Φ	I _N (A)	T _{st} /T _N	T _{max} /T _N	I _{st} /I _N	L _w dB (A)	J (kg.m ²)
056M	0.09	440	60	Y	1610	0.5	-	62	0.63	0.3	2.8	3.2	3.1	53	0.0003
063M	0.12	440	60	Y	1665	0.7	IE3	66	0.66	0.4	2.6	3.1	3.9	53	0.00034
063M	0.18	440	60	Y	1675	1.0	IE3	69.5	0.68	0.5	2.8	3.2	4.2	53	0.00051
071M	0.25	440	60	Y	1690	1.4	IE3	73.4	0.7	0.65	3.0	3.3	4.9	53	0.00074
071M	0.37	440	60	Y	1695	2.1	IE3	78.2	0.71	0.9	3.2	3.3	5.3	53	0.00099
080M	0.55	440	60	Y	1735	3.0	IE3	82.5	0.73	1.3	2.9	3.2	6.4	56	0.0019
080M	0.75	440	60	Y	1730	4.1	IE3	85.5	0.75	1.6	2.7	3.0	6.4	56	0.00249
090S	1.1	440	60	Y	1740	6.0	IE3	86.5	0.76	2.3	2.8	2.9	7.1	59	0.00351
090M	1.5	440	60	Y	1740	8.2	IE3	86.5	0.77	3.1	3.0	2.9	7.4	59	0.00442
100M	2.2	440	60	Y	1755	12.0	IE3	89.5	0.8	4.2	2.8	3.4	8.0	64	0.00926
100M	3	440	60	Y	1755	16.3	IE3	89.5	0.8	5.6	3.0	3.4	8.3	64	0.0113
112L	4	440	60	△	1755	21.8	IE3	89.5	0.82	7.3	2.2	2.9	7.1	65	0.0143
132M	5.5	440	60	△	1765	29.8	IE3	91.7	0.83	9.6	2.1	2.8	7.6	71	0.0307
132L	7.5	440	60	△	1765	40.6	IE3	91.7	0.84	13	2.1	2.7	7.5	71	0.0382
160M	11	440	60	△	1775	59.2	IE3	92.4	0.83	19	2.3	3.6	7.9	73	0.095
160L	15	440	60	△	1775	80.7	IE3	93	0.83	25.6	2.4	3.5	8.0	73	0.12
180M	18.5	440	60	△	1775	99.5	IE3	93.6	0.85	31	2.5	3.6	8.6	76	0.169
180L	22	440	60	△	1775	118.4	IE3	93.6	0.85	36.5	2.5	3.6	8.5	76	0.195
200M	30	440	60	△	1780	161.0	IE3	94.1	0.85	49.5	2.7	3.1	7.1	76	0.317
225M	37	440	60	△	1785	198.0	IE3	94.5	0.86	60.5	2.7	3.1	7.9	78	0.555
225M	45	440	60	△	1785	240.8	IE3	95	0.86	73	2.6	2.9	7.5	78	0.621
250M	55	440	60	△	1785	294.3	IE3	95.4	0.86	88.5	2.5	3.1	7.8	79	0.839
280S	75	440	60	△	1790	400.1	IE3	95.4	0.86	120	2.6	3.0	7.4	80	1.592
280M	90	440	60	△	1790	480.2	IE3	95.4	0.86	144	2.8	3.1	7.7	80	1.887

60Hz 460V 4P-1800r/min S1

Frame size	P _N (kW)	U _N (V)	F _N (Hz)	Conn.	n _N (r/min)	T _N (N.m)	IE-CL	η(%)	COS Φ	I _N (A)	T _{st} /T _N	T _{max} /T _N	I _{st} /I _N	L _w dB (A)	J (kg.m ²)
056M	0.09	460	60	Y	1610	0.5	-	62	0.63	0.3	3.2	3.5	3.2	53	0.0003
063M	0.12	460	60	Y	1675	0.7	IE3	66	0.63	0.4	2.9	3.4	4.0	53	0.00034
063M	0.18	460	60	Y	1680	1.0	IE3	69.5	0.65	0.5	3.0	3.5	4.4	53	0.00051
071M	0.25	460	60	Y	1700	1.4	IE3	73.4	0.67	0.65	3.4	3.6	5.2	53	0.00074
071M	0.37	460	60	Y	1705	2.1	IE3	78.2	0.68	0.9	3.7	3.6	5.6	53	0.00099
080M	0.55	460	60	Y	1740	3.0	IE3	82.5	0.7	1.3	3.4	3.6	7.0	56	0.0019
080M	0.75	460	60	Y	1740	4.1	IE3	85.5	0.73	1.6	3.2	3.3	7.0	56	0.00249
090S	1.1	460	60	Y	1745	6.0	IE3	86.5	0.74	2.3	3.3	3.2	7.5	59	0.00351
090M	1.5	460	60	Y	1745	8.2	IE3	86.5	0.74	3	3.6	3.2	7.8	59	0.00442
100M	2.2	460	60	Y	1760	11.9	IE3	89.5	0.77	4.2	3.2	3.8	8.7	64	0.00926
100M	3	460	60	Y	1760	16.3	IE3	89.5	0.77	5.6	3.5	3.8	9.1	64	0.0113
112L	4	460	60	△	1760	21.7	IE3	89.5	0.8	7.3	2.6	3.3	8.0	65	0.0143
132M	5.5	460	60	△	1770	29.7	IE3	91.7	0.81	9.4	2.5	3.2	8.6	71	0.0307
132L	7.5	460	60	△	1770	40.5	IE3	91.7	0.82	12.7	2.5	3.0	8.6	71	0.0382
160M	11	460	60	△	1775	59.2	IE3	92.4	0.82	18.5	2.7	4.0	8.7	73	0.095
160L	15	460	60	△	1775	80.7	IE3	93	0.82	25	2.8	3.9	8.7	73	0.12
180M	18.5	460	60	△	1780	99.3	IE3	93.6	0.83	30	2.7	3.8	8.9	76	0.169
180L	22	460	60	△	1780	118.0	IE3	93.6	0.83	36	2.8	3.9	9.2	76	0.195
200M	30	460	60	△	1780	161.0	IE3	94.1	0.83	48.5	3.1	3.4	7.8	76	0.317
225M	37	460	60	△	1785	198.0	IE3	94.5	0.84	59	3.1	3.4	8.8	78	0.555
225M	45	460	60	△	1785	240.8	IE3	95	0.85	70.5	3.0	3.2	8.4	78	0.621
250M	55	460	60	△	1785	294.3	IE3	95.4	0.84	86.5	3.0	3.4	8.7	79	0.839
280S	75	460	60	△	1790	400.1	IE3	95.4	0.85	117	3.0	3.3	8.2	80	1.592
280M	90	460	60	△	1790	480.2	IE3	95.4	0.85	140	3.2	3.4	8.5	80	1.887

60Hz 440V 6P-1200r/min S1

Frame size	PN (kW)	UN (V)	FN (Hz)	Conn.	n_N (r/min)	T_N (N.m)	IE-CL	η (%)	COS Φ	I_N (A)	T_{st}/T_N	T_{max}/T_N	I_{st}/I_N	LwdB (A)	J (kg.m ²)
071M	0.18	440	60	Y	1105	1.6	IE3	67.5	0.62	0.6	2.6	3.1	3.5	51	0.00115
071M	0.25	440	60	Y	1105	2.2	IE3	71.4	0.64	0.75	2.5	3.0	3.5	51	0.0013
080M	0.37	440	60	Y	1145	3.1	IE3	75.3	0.68	1	2.4	3.0	4.8	54	0.00227
080M	0.55	440	60	Y	1145	4.6	IE3	81.7	0.7	1.3	2.3	2.9	5.0	54	0.0032
090S	0.75	440	60	Y	1150	6.2	IE3	82.5	0.7	1.8	2.2	2.8	4.9	57	0.00418
090M	1.1	440	60	Y	1150	9.1	IE1	83	0.71	2.6	2.2	2.8	5.1	57	0.00599
100M	1.5	440	60	Y	1160	12.3	IE1	84.5	0.71	3.4	2.7	3.0	6.0	61	0.0117
112M	2.2	440	60	Y	1165	18.0	IE2	87.5	0.73	4.7	2.3	2.7	6.0	65	0.0171
132S	3	440	60	Y	1175	24.4	IE2	87.5	0.73	6.2	2.4	2.7	6.9	69	0.0332
132M	4	440	60	Δ	1175	32.5	IE2	87.5	0.74	8.1	2.5	2.7	7.2	69	0.043
132L	5.5	440	60	Δ	1175	44.7	IE2	89.5	0.75	11	2.4	2.6	7.1	69	0.0571
160S	7.5	440	60	Δ	1175	61.0	IE3	91	0.78	13.9	2.1	3.1	6.0	73	0.104
160M	11	440	60	Δ	1175	89.4	IE3	91.7	0.78	20.5	2.3	3.1	6.3	73	0.146
180M	15	440	60	Δ	1185	120.9	IE3	91.7	0.81	27	2.4	3.1	8.1	73	0.232
200M	18.5	440	60	Δ	1185	149.1	IE3	93	0.8	33	2.3	2.9	6.5	73	0.374
200M	22	440	60	Δ	1185	177.3	IE3	93	0.8	39	2.3	2.8	6.4	73	0.417
225M	30	440	60	Δ	1185	241.8	IE3	94.1	0.82	51.5	2.4	2.6	7.0	74	0.625
250M	37	440	60	Δ	1185	298.2	IE3	94.1	0.83	62.5	2.5	3.1	7.0	76	1.063
280S	45	440	60	Δ	1190	361.1	IE3	94.5	0.83	75.5	2.4	3.0	7.3	78	1.675
280M	55	440	60	Δ	1190	441.4	IE3	94.5	0.84	91	2.5	2.9	7.3	78	2.02

60Hz 460V 6P-1200r/min S1

Frame size	PN (kW)	UN (V)	FN (Hz)	Conn.	n_N (r/min)	T_N (N.m)	IE-CL	η (%)	COS Φ	I_N (A)	T_{st}/T_N	T_{max}/T_N	I_{st}/I_N	LwdB (A)	J (kg.m ²)
071M	0.18	460	60	Y	1110	1.5	IE3	67.5	0.59	0.6	2.9	3.4	3.6	51	0.00115
071M	0.25	460	60	Y	1110	2.2	IE3	71.4	0.61	0.75	2.8	3.3	3.7	51	0.0013
080M	0.37	460	60	Y	1150	3.1	IE3	75.3	0.65	1	2.7	3.3	5.1	54	0.00227
080M	0.55	460	60	Y	1150	4.6	IE3	81.7	0.68	1.3	2.7	3.2	5.3	54	0.0032
090S	0.75	460	60	Y	1155	6.2	IE3	82.5	0.67	1.8	2.6	3.2	5.3	57	0.00418
090M	1.1	460	60	Y	1155	9.1	IE1	83	0.68	2.6	2.6	3.1	5.5	57	0.00599
100M	1.5	460	60	Y	1160	12.3	IE1	84.5	0.68	3.3	3.2	3.3	6.6	61	0.0117
112M	2.2	460	60	Y	1165	18.0	IE2	87.5	0.71	4.6	2.8	3.0	6.6	65	0.0171
132S	3	460	60	Y	1175	24.4	IE2	87.5	0.71	6.2	3.0	3.1	7.7	69	0.0332
132M	4	460	60	Δ	1175	32.5	IE2	87.5	0.72	8	3.1	3.1	8.1	69	0.043
132L	5.5	460	60	Δ	1175	44.7	IE2	89.5	0.73	10.5	2.9	2.9	8.1	69	0.0571
160S	7.5	460	60	Δ	1175	61.0	IE3	91	0.75	13.8	2.5	3.4	6.6	73	0.104
160M	11	460	60	Δ	1175	89.4	IE3	91.7	0.75	20.1	2.7	3.5	7.0	73	0.146
180M	15	460	60	Δ	1185	120.9	IE3	91.7	0.78	26.5	2.9	3.5	8.9	73	0.232
200M	18.5	460	60	Δ	1185	149.1	IE3	93	0.78	32.5	2.7	3.2	7.2	73	0.374
200M	22	460	60	Δ	1185	177.3	IE3	93	0.78	38.5	2.7	3.1	7.1	73	0.417
225M	30	460	60	Δ	1190	240.8	IE3	94.1	0.8	50.5	2.8	3.0	7.8	74	0.625
250M	37	460	60	Δ	1190	296.9	IE3	94.1	0.81	61	2.9	3.4	7.7	76	1.063
280S	45	460	60	Δ	1190	361.1	IE3	94.5	0.82	73	2.8	3.3	8.1	78	1.675
280M	55	460	60	Δ	1190	441.4	IE3	94.5	0.83	88.5	2.8	3.3	8.1	78	2.02

10 MH motor dimensions

B3 mounting construction

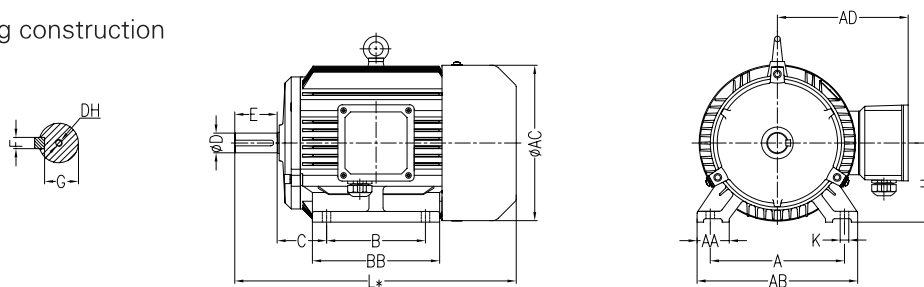

Frame size	No. of poles	Dimension (mm)														
		A	B	C	D	E	F	G	H	K	AA	AB	AC	AD	BB	DH
063M	4	100	80	40	11	23	4	8.5	63	7	35	124	124	113	102	CM4L10/7.4
071M	4、6	112	90	45	14	30	5	11	71	8	39	141	139	123	115	CM5L10/8.8
080M	4、6	125	100	50	19	40	6	15.5	80	10	40	165	159	167	132	CM6L12/10.5
090S	4、6	140	100	56	24	50	8	20	90	10	44	180	176	190	160	CM8L12/13.2
	4、6	140	125	56	24	50	8	20	90	10	44	180	176	190	160	CM8L12/13.2
100M	4、6	160	140	63	28	60	8	24	100	12	48	205	199	200	176	CM10L15/16.3
112M	6	190	140	70	28	60	8	24	112	12	45	230	220	220	180	CM10L15/16.3
112L	4	190	140	70	28	60	8	24	112	12	45	230	220	220	248	CM10L15/16.3
132S	4、6	216	140	89	38	80	10	33	132	12	55	270	259	240	186	CM12L20/19.8
132M	4、6	216	178	89	38	80	10	33	132	12	55	270	259	240	224	CM12L20/19.8
160S	4、6	254	210	108	42	110	12	37	160	14.5	65	320	314	285	260	CM16L25/25.3
160M	4、6	254	254	108	42	110	12	37	160	14.5	65	320	314	285	304	CM16L25/25.3
180M	4	279	241	121	48	110	14	42.5	180	14.5	70	355	356	310	349	CM16L25/25.3
180M	6	279	279	121	48	110	14	42.5	180	14.5	70	355	356	310	349	CM16L25/25.3
180L	4	279	279	121	48	110	14	42.5	180	14.5	70	355	356	310	397	CM16L25/25.3
200M	4、6	318	305	133	55	110	16	49	200	18.5	70	395	398	335	369	CM20L30/31.3
	4、6	356	286	149	60	140	18	53	225	18.5	75	435	446	370	393	CM20L30/31.3
225M	4、6	356	311	149	60	140	18	53	225	18.5	75	435	446	370	393	CM20L30/31.3
	4、6	356	311	149	60	140	18	53	225	18.5	75	435	446	370	393	CM20L30/31.3
250M	4、6	406	349	168	65	140	18	58	250	24	80	490	485	380	445	CM20L30/31.3
280S	4、6	457	368	190	75	140	20	67.5	280	24	85	550	547	410	485	CM20L30/31.3
280M	4、6	457	419	190	75	140	20	67.5	280	24	85	550	547	410	536	CM20L30/31.3

B5 mounting construction

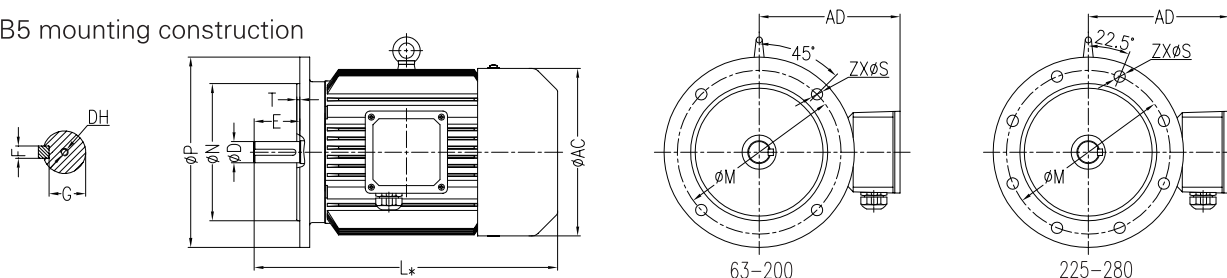

Frame size	No. of poles	Dimension (mm)												
		D	E	F	G	M	N	P	S	T	Z	AC	AD	DH
063M	4	11	23	4	8.5	115	95	140	10	3	4	124	113	CM4L10/7.4
071M	4、6	14	30	5	11	130	110	160	10	3	4	139	123	CM5L10/8.8
080M	4、6	19	40	6	15.5	165	130	200	12	3.5	4	159	167	CM6L12/10.5
090S	4、6	24	50	8	20	165	130	200	12	3.5	4	176	190	CM8L12/13.2
100M	4、6	28	60	8	24	215	180	250	14.5	4	4	199	200	CM10L15/16.3
112M	6	28	60	8	24	215	180	250	14.5	4	4	220	220	CM10L15/16.3
112L	4	28	60	8	24	215	180	250	14.5	4	4	220	220	CM10L15/16.3
132S	4、6	38	80	10	33	265	230	300	14.5	4	4	259	240	CM12L20/19.8
132M	4、6	38	80	10	33	265	230	300	14.5	4	4	259	240	CM12L20/19.8
160S	4、6	42	110	12	37	300	250	350	18.5	5	4	314	285	CM16L25/25.3
160M	4、6	42	110	12	37	300	250	350	18.5	5	4	314	285	CM16L25/25.3
180M	4、6	48	110	14	42.5	300	250	350	18.5	5	4	356	310	CM16L25/25.3
180L	4	48	110	14	42.5	300	250	350	18.5	5	4	356	310	CM16L25/25.3
200M	4、6	55	110	16	49	350	300	400	18.5	5	4	398	335	CM20L30/31.3
225M	4、6	60	140	18	53	400	350	450	18.5	5	8	446	370	CM20L30/31.3
250M	4、6	65	140	18	58	500	450	550	18.5	5	8	485	380	CM20L30/31.3
280S	4、6	75	140	20	67.5	500	450	550	18.5	5	8	547	410	CM20L30/31.3
280M	4、6	75	140	20	67.5	500	450	550	18.5	5	8	547	410	CM20L30/31.3

B14B mounting construction

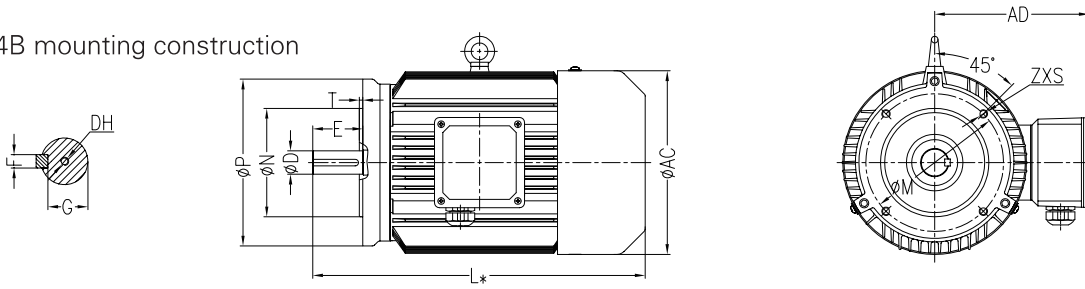

Frame size	No. of poles	Dimension (mm)												
		D	E	F	G	M	N	P	S	T	Z	AC	AD	DH
071M	4、6	14	30	5	11	115	95	140	M8	3	4	139	123	CM5L10/8.8
080M	4、6	19	40	6	15.5	130	110	160	M8	3.5	4	159	167	CM6L12/10.5
090S	4、6	24	50	8	20	130	110	160	M8	3.5	4	176	190	CM8L12/13.2
100M	4、6	28	60	8	24	165	130	200	M10	4	4	199	200	CM10L15/16.3
112M	6	28	60	8	24	165	130	200	M10	4	4	220	220	CM10L15/16.3
112L	4	28	60	8	24	165	130	200	M10	4	4	220	220	CM10L15/16.3
132S	4、6	38	80	10	33	215	180	250	M12	4	4	259	240	CM12L20/19.8
132M	4、6	38	80	10	33	215	180	250	M12	4	4	259	240	CM12L20/19.8

MH motor dimensions (continue)

MH motor length and weight

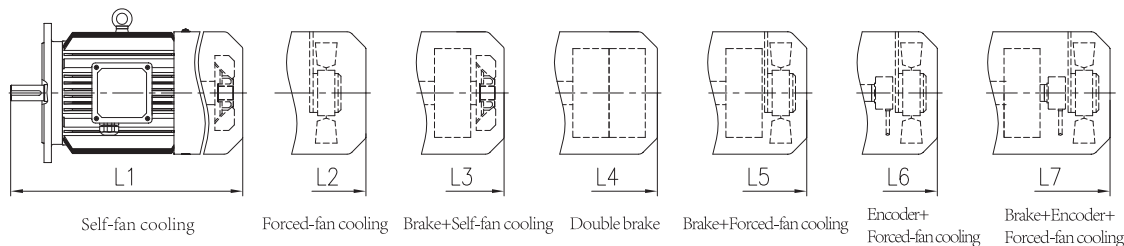

Frame size	4-pole power (kW)	Motor length L* (mm)							Motor weight (kg)						
		L1	L2	L3	L4	L5	L6	L7	M1	M2	M3	M4	M5	M6	M7
63M	0.12	215	270	250	/	305	/	/	7	7.5	8.5	/	9	/	/
63M	0.18	215	270	250	/	305	/	/	7	7.5	8.5	/	9	/	/
71M	0.25	244	294	284	/	339	339	379	8	9	9.5	/	10.5	9.5	11.5
71M	0.37	244	294	284	/	339	339	379	9	10	10.5	/	11.5	10.5	12.5
80M	0.55	301	346	361	/	406	406	451	14	15	18	23	19	15.5	20
80M	0.75	301	346	361	/	406	406	451	15	16	19	24	20	16.5	21
90S	1.1	334	379	389	/	439	439	484	18	19	22	27	23	19.5	24
90S	1.5	334	379	389	/	439	439	484	19	20	23	28	24	20.5	25
100M	2.2	409	464	484	/	544	544	589	30	31	38	47	39	32	40
100M	3	409	464	484	/	544	544	589	33	34	41	50	42	35	43
112L	4	472	532	547	/	612	612	652	52	53	60	69	61	54	62
132S	5.5	465	530	545	/	615	615	645	67	69	78	91	80	70	81
132M	7.5	503	568	583	/	653	653	683	80	82	91	104	93	83	94
160S	11	601	651	696	746	751	751	786	121	123	142	164	143	124	144
160M	15	645	695	740	790	795	795	830	139	141	160	182	161	142	162
180M	18.5	706	751	816	871	861	861	901	182	184	214	249	215	185	217
180L	22	754	799	864	920	909	909	949	204	206	236	271	237	207	239
200M	30	797	817	912	927	937	937	987	260	260	310	363	308	261	310
225M	37	869	904	984	/	1024	1024	1064	330	332	380	/	381	334	383
225M	45	869	904	984	/	1024	1024	1064	345	347	395	/	396	349	398
250M	55	964	989	1104	/	1144	1144	1174	435	436	540	/	535	435	537
280S	75	1011	1041	1151	/	1191	1191	1231	575	577	680	/	678	578	680
280M	90	1062	1092	1202	/	1242	1242	1282	645	647	750	/	748	648	750
Frame size	6-pole power (kW)	Motor length L* (mm)							Motor weight (kg)						
		L1	L2	L3	L4	L5	L6	L7	M1	M2	M3	M4	M5	M6	M7
71M	0.18	244	294	284	/	339	339	379	9.5	10.5	11	/	12	11	13
71M	0.25	244	294	284	/	339	339	379	10	11	11.5	/	12.5	11.5	13.5
80M	0.37	301	346	361	/	406	406	451	14	15	18	23	19	15.5	20
80M	0.55	301	346	361	/	406	406	451	15	16	19	24	20	16.5	21
90S	0.75	334	379	389	/	439	439	484	17	18	21	26	22	18.5	23
90S	1.1	334	379	389	/	439	439	484	18.5	19.5	22.5	27.5	23.5	20	24.5
100M	1.5	409	464	484	/	544	544	589	27	28	35	44	36	29	37
112M	2.2	404	464	479	/	544	544	584	43	44	51	60	52	45	53
132S	3	465	530	545	/	615	615	645	61	63	72	85	74	64	75
132M	4	503	568	583	/	653	653	683	66	68	77	90	79	69	80
132M	5.5	503	568	583	/	653	653	683	80	82	91	104	93	83	94
160S	7.5	601	651	696	/	751	751	786	115	117	136	158	137	118	138
160M	11	645	695	740	/	795	795	830	135	137	156	178	157	138	158
180M	15	706	751	816	/	861	861	901	188	190	220	255	221	191	223
200M	18.5	797	817	912	/	937	937	987	235	235	285	338	283	236	285
200M	22	797	817	912	/	937	937	987	255	255	305	358	303	256	305
225M	30	869	904	984	/	1024	1024	1064	320	322	370	/	371	324	373
250M	37	959	989	1099	/	1144	1144	1174	420	421	525	/	520	420	522
280S	45	1011	1041	1151	/	1191	1191	1231	535	537	640	/	638	538	640
280M	55	1062	1092	1202	/	1242	1242	1282	600	602	705	/	703	603	705

11 MP motor dimensions

B3 mounting construction

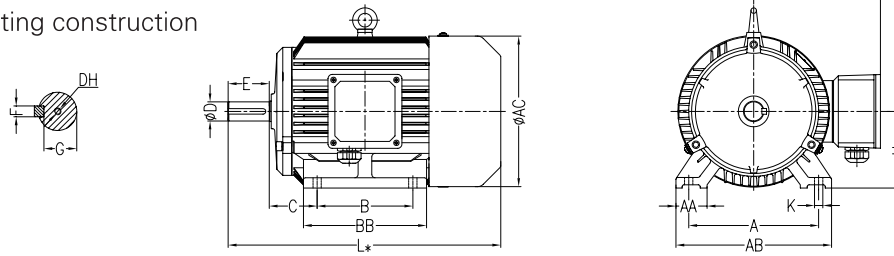

Frame size	No. of poles	Dimension (mm)														
		A	B	C	D	E	F	G	H	K	AA	AB	AC	AD	BB	DH
063M	4	100	80	40	11	23	4	8.5	63	7	35	124	124	113	102	CM4L10/7.4
071M	4、6	112	90	45	14	30	5	11	71	8	39	141	139	123	115	CM5L10/8.8
080M	4、6	125	100	50	19	40	6	15.5	80	10	40	165	159	167	132	CM6L12/10.5
090S	4、6	140	100	56	24	50	8	20	90	10	44	180	176	190	160	CM8L12/13.2
090M	4、6	140	125	56	24	50	8	20	90	10	44	180	176	190	160	CM8L12/13.2
100M	4、6	160	140	63	28	60	8	24	100	12	48	205	199	200	176	CM10L15/16.3
112M	6	190	140	70	28	60	8	24	112	12	45	230	220	220	180	CM10L15/16.3
112L	4	190	140	70	28	60	8	24	112	12	45	230	220	220	180	CM10L15/16.3
132S	6	216	140	89	38	80	10	33	132	12	55	270	259	240	186	CM12L20/19.8
132M	4	216	140	89	38	80	10	33	132	12	55	270	259	240	224	CM12L20/19.8
132M	6	216	178	89	38	80	10	33	132	12	55	270	259	240	224	CM12L20/19.8
132L	4、6	216	178	89	38	80	10	33	132	12	55	270	259	240	262	CM12L20/19.8
160S	6	254	210	108	42	110	12	37	160	14.5	65	320	314	285	260	CM16L25/25.3
160M	4	254	210	108	42	110	12	37	160	14.5	65	320	314	285	304	CM16L25/25.3
160M	6	254	254	108	42	110	12	37	160	14.5	65	320	314	285	304	CM16L25/25.3
160L	4	254	254	108	42	110	12	37	160	14.5	65	320	314	285	334	CM16L25/25.3
180M	4	279	241	121	48	110	14	42.5	180	14.5	70	355	356	310	349	CM16L25/25.3
180M	6	279	279	121	48	110	14	42.5	180	14.5	70	355	356	310	349	CM16L25/25.3
180L	4	279	279	121	48	110	14	42.5	180	14.5	70	355	356	310	397	CM16L25/25.3
200M	4、6	318	305	133	55	110	16	49	200	18.5	70	395	398	335	369	CM20L30/31.3
225M	4、6	356	286	149	60	140	18	53	225	18.5	75	435	446	370	393	CM20L30/31.3
	4、6	356	311	149	60	140	18	53	225	18.5	75	435	446	370	393	CM20L30/31.3
250M	4、6	406	349	168	65	140	18	58	250	24	80	490	485	380	445	CM20L30/31.3
280S	4、6	457	368	190	75	140	20	67.5	280	24	85	550	547	410	485	CM20L30/31.3
280M	4、6	457	419	190	75	140	20	67.5	280	24	85	550	547	410	536	CM20L30/31.3

B5 mounting construction

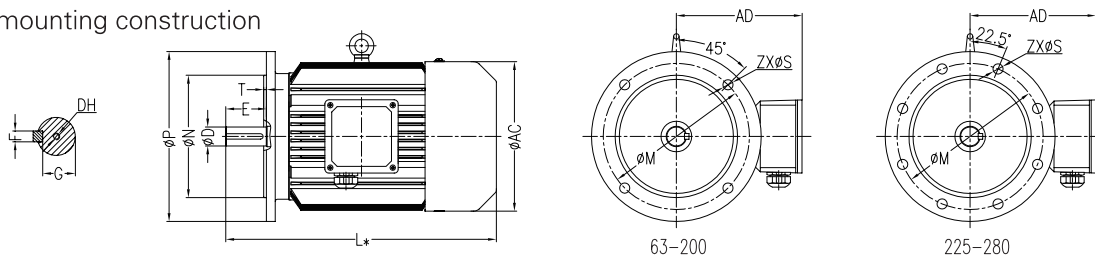

Frame size	No. of poles	Dimension (mm)												
		D	E	F	G	M	N	P	S	T	Z	AC	AD	DH
063M	4	11	23	4	8.5	115	95	140	10	3	4	124	113	CM4L10/7.4
071M	4、6	14	30	5	11	130	110	160	10	3	4	139	123	CM5L10/8.8
080M	4、6	19	40	6	15.5	165	130	200	12	3.5	4	159	167	CM6L12/10.5
090S	4、6	24	50	8	20	165	130	200	12	3.5	4	176	190	CM8L12/13.2
090M	4、6	24	50	8	20	165	130	200	12	3.5	4	176	190	CM8L12/13.2
100M	4、6	28	60	8	24	215	180	250	14.5	4	4	199	200	CM10L15/16.3
112M	6	28	60	8	24	215	180	250	14.5	4	4	220	220	CM10L15/16.3
112L	4	28	60	8	24	215	180	250	14.5	4	4	220	220	CM10L15/16.3
132S	6	38	80	10	33	265	230	300	14.5	4	4	259	240	CM12L20/19.8
132M	4、6	38	80	10	33	265	230	300	14.5	4	4	259	240	CM12L20/19.8
132L	4、6	38	80	10	33	265	230	300	14.5	4	4	259	240	CM12L20/19.8
160S	6	42	110	12	37	300	250	350	18.5	5	4	314	285	CM16L25/25.3
160M	4、6	42	110	12	37	300	250	350	18.5	5	4	314	285	CM16L25/25.3
160L	4	42	110	12	37	300	250	350	18.5	5	4	314	285	CM16L25/25.3
180M	4、6	48	110	14	42.5	300	250	350	18.5	5	4	356	310	CM16L25/25.3
180L	4	48	110	14	42.5	300	250	350	18.5	5	4	356	310	CM16L25/25.3
200M	4、6	55	110	16	49	350	300	400	18.5	5	4	398	335	CM20L30/31.3
225M	4、6	60	140	18	53	400	350	450	18.5	5	8	446	370	CM20L30/31.3
250M	4、6	65	140	18	58	500	450	550	18.5	5	8	485	380	CM20L30/31.3
280S	4、6	75	140	20	67.5	500	450	550	18.5	5	8	547	410	CM20L30/31.3
280M	4、6	75	140	20	67.5	500	450	550	18.5	5	8	547	410	CM20L30/31.3

B14 mounting construction

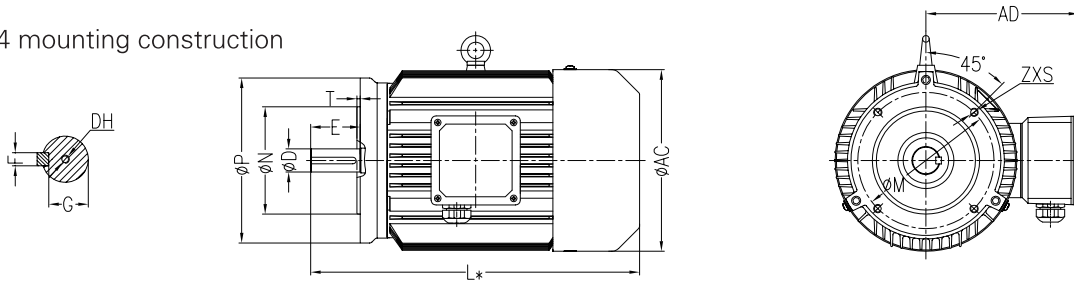

Frame size	No. of poles	Dimension (mm)												
		D	E	F	G	M	N	P	S	T	Z	AC	AD	DH
071M	4、6	14	30	5	11	115	95	140	M8	3	4	139	123	CM5L10/8.8
080M	4、6	19	40	6	15.5	130	110	160	M8	3.5	4	159	167	CM6L12/10.5
090S	4、6	24	50	8	20	130	110	160	M8	3.5	4	176	190	CM8L12/13.2
090M	4、6	24	50	8	20	130	110	160	M8	3.5	4	176	190	CM8L12/13.2
100M	4、6	28	60	8	24	165	130	200	M10	4	4	199	200	CM10L15/16.3
112M	6	28	60	8	24	165	130	200	M10	4	4	220	220	CM10L15/16.3
112L	4	28	60	8	24	165	130	200	M10	4	4	220	220	CM10L15/16.3
132S	6	38	80	10	33	215	180	250	M12	4	4	259	240	CM12L20/19.8
132M	4、6	38	80	10	33	215	180	250	M12	4	4	259	240	CM12L20/19.8
132L	4、6	38	80	10	33	215	180	250	M12	4	4	259	240	CM12L20/19.8

MP motor dimensions (continue)

MP motor length and weight

Frame size	4-pole power (kW)	Motor length L* (mm)						Motor weight (kg)						
		L1	L2	L3	L5	L6	L7	M1	M2	M3	M5	M6	M7	
063M	0.12	215	270	250	305	/	/	7	7.5	8.5	9	/	/	
063M	0.18	215	270	250	305	/	/	8	8.5	9.5	10	/	/	
071M	0.25	244	294	284	339	339	379	9	10	10.5	11.5	10.5	12.5	
071M	0.37	244	294	284	339	339	379	10	11	11.5	12.5	11.5	13.5	
080M	0.55	301	346	361	406	406	451	15	16	19	20	16.5	21	
080M	0.75	301	346	361	406	406	451	16	17	20	21	17.5	22	
090S	1.1	334	379	389	439	439	484	21	22	25	26	22.5	27	
090M	1.5	359	404	414	464	464	509	23	24	27	28	24.5	29	
100M	2.2	409	464	484	544	544	589	32	33	40	41	34	41	
100M	3	409	464	484	544	544	589	36	37	44	45	38	45	
112L	4	472	532	547	612	612	652	56	57	64	65	58	66	
132M	5.5	503	568	583	653	653	683	77	79	88	90	80	91	
132L	7.5	541	606	621	691	691	721	88	90	99	101	91	102	
160M	11	645	695	740	795	795	830	129	131	150	151	132	152	
160L	15	675	725	770	825	825	860	161	163	182	183	164	184	
180M	18.5	706	751	816	861	861	901	200	202	232	233	203	235	
180L	22	754	799	864	909	909	949	220	222	252	253	223	255	
200M	30	797	817	912	937	937	987	280	280	330	328	281	330	
225M	37	869	904	984	1024	1024	1064	345	347	395	396	349	398	
225M	45	869	904	984	1024	1024	1064	365	367	415	416	369	418	
250M	55	964	989	1104	1144	1144	1174	470	471	575	570	470	572	
280S	75	1011	1041	1151	1191	1191	1231	630	632	735	733	633	735	
280M	90	1062	1092	1202	1242	1242	1282	710	712	815	813	713	815	
Frame size	4-pole power (kW)	Motor length L* (mm)						Motor weight (kg)						
		L1	L2	L3	L5	L6	L7	M1	M2	M3	M5	M6	M7	
71M	0.18	244	294	284	339	339	379	10.5	11.5	12	13	12	14	
71M	0.25	244	294	284	339	339	379	12	13	13.5	14.5	13.5	15.5	
80M	0.37	301	346	361	406	406	451	15	16	19	20	16.5	21	
80M	0.55	301	346	361	406	406	451	17	18	21	22	18.5	23	
90S	0.75	334	379	389	439	439	484	20	21	24	25	21.5	26	
90M	1.1	359	404	414	464	464	509	25	26	29	30	26.5	31	
100M	1.5	409	464	484	544	544	589	32	33	40	41	34	42	
112M	2.2	404	464	479	544	544	584	51	52	59	60	53	61	
132S	3	465	530	545	615	615	645	63	65	74	76	66	77	
132M	4	503	568	583	653	653	683	69	71	80	82	72	83	
132L	5.5	541	606	621	691	691	721	88	90	99	101	91	102	
160S	7.5	601	651	696	751	751	786	117	119	138	139	120	140	
160M	11	645	695	740	795	795	830	161	163	182	183	164	184	
180M	15	706	751	816	861	861	901	200	202	232	233	203	235	
200M	18.5	797	817	912	937	937	987	230	230	280	278	231	280	
200M	22	797	817	912	937	937	987	260	260	310	308	261	310	
225M	30	869	904	984	1024	1024	1064	330	332	380	381	334	383	
250M	37	959	989	1099	1144	1144	1174	435	436	540	535	435	537	
280S	45	1011	1041	1151	1191	1191	1231	545	547	650	648	548	650	
280M	55	1062	1092	1202	1242	1242	1282	605	607	710	708	608	710	

12 Dimensions of motor shaft projecting tail and rainproof cover

◆ Dimensions of motor shaft projecting tail

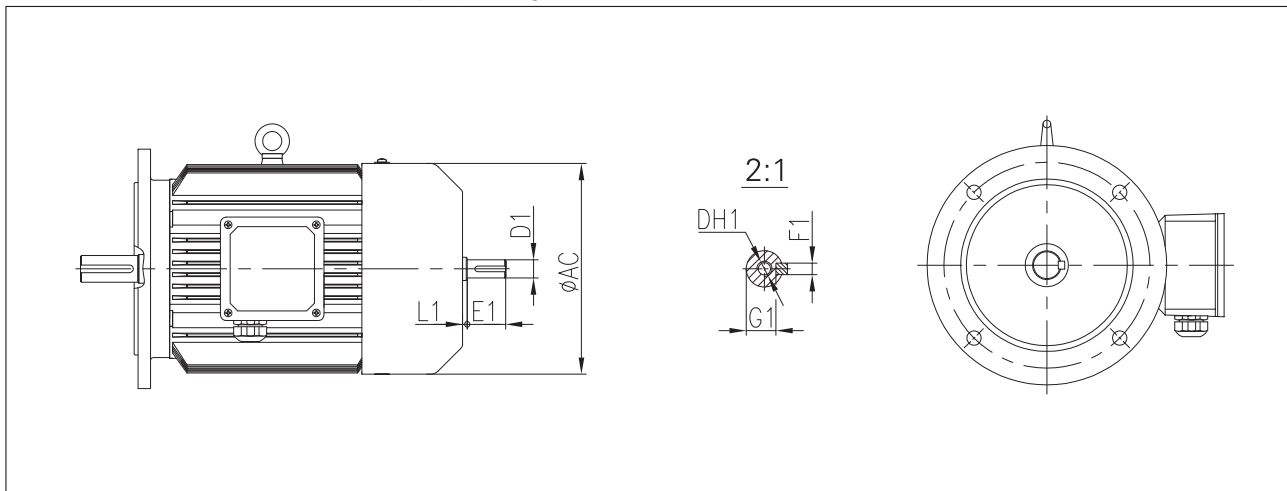

Frame size							
	D1	E1	F1	G1	L1	DH1	AC
80	Please inquire						
90							
100							
112							
132							
160							
180							
200							
225							
250							
280							

◆ Dimensions of rainproof cover

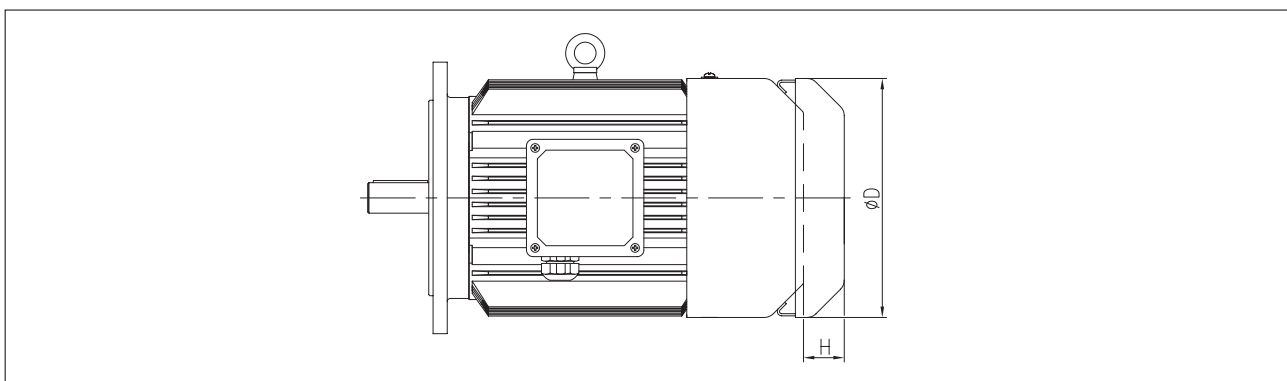

Frame size	H63	H71	H80	H90	H100	H112	H132	H160	H180	H200	H225	H250	H280
D	124	139	159	176	199	220	259	314	356	398	446	485	547
H	25	30	30	35	40	40	40	60	60	70	70	80	80

13 Electrical connection schematics

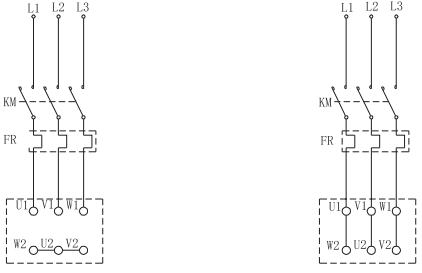
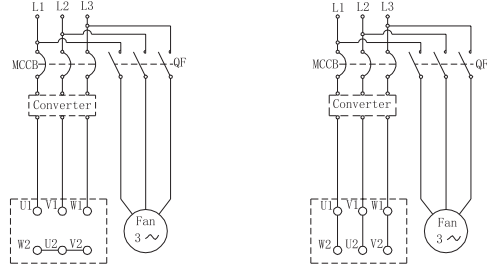
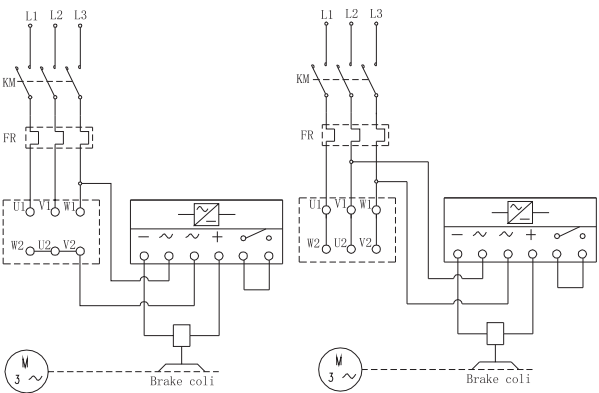
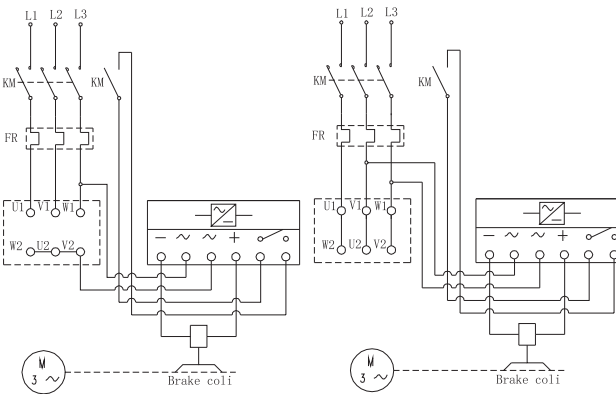
<p style="writing-mode: vertical-rl; transform: rotate(180deg);">Basic wiring diagram</p>	<p>1) Self-fan cooling motor</p> 	<p>2) Forced-fan cooling motor</p> 
	<p style="writing-mode: vertical-rl; transform: rotate(180deg);">Slow brake wiring diagram (factory standard)</p>	<p>3) Motor with brake</p> 
<p style="writing-mode: vertical-rl; transform: rotate(180deg);">Rapid brake wiring diagram (customer connection)</p>		

Along with the technology advancedet.,the product of the manual of Boneng will be changed,please forgive.

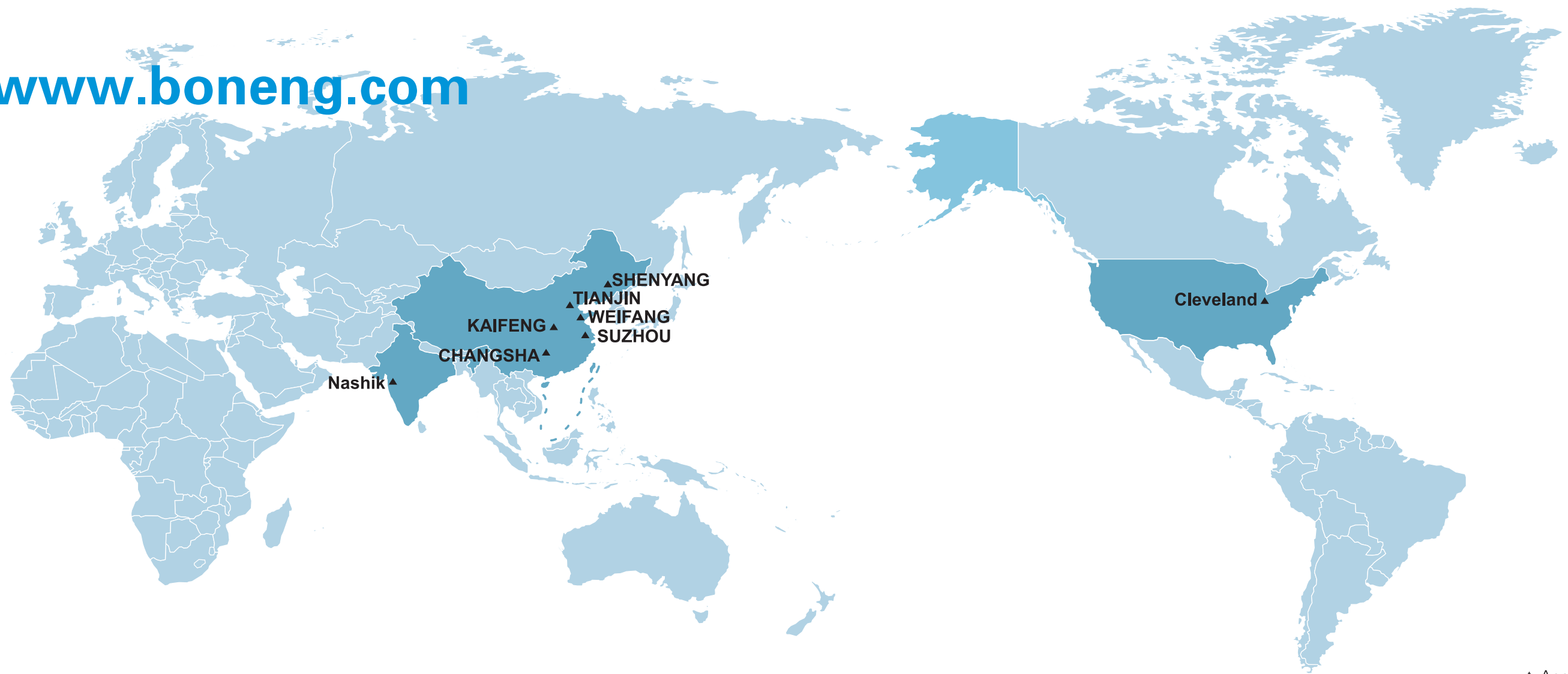

▲ Assembly Company

BONENG TRANSMISSION(INDIA)PVT.LTD

Plot No. E-10/3, MIDC sinner (Malegaon)
Industrial Area, Nashik, 422123,
Maharashtra, India.
TEL:+91-11- 4507 6293 (DELHI)
TEL:+91-22-2781 3385 (MUMBAI)

BONENG TRANSMISSION(SUZHOU)CO.,LTD.

No. 100, Ruyuan Road, Xiangcheng District, 215131
Suzhou, Jiangsu Province, China
TEL: 0512-66189662

BONENG TRANSMISSION(SHENYANG)CO.,LTD.

No. A73-6, Area A, Pacific Industrial City, Shenbei 110013
New District, Shenyang, Liaoning Province, China
TEL: 024-31271571

BONENG TRANSMISSION(TIANJIN)CO.,LTD.

7th Workshop, Hongpeng Industrial Park, No. 6 300021
Shuanghai Road, Beichen District, Tianjin City,China
TEL: 022-26929556

BONENG TRANSMISSION(WEIFANG)CO.,LTD.

1st Workshop, Economic Development Zone, Anqiu, 261000
Weifang City, Shandong Province, China
TEL: 0536-2141166

BONENG TRANSMISSION(KAIFENG)CO.,LTD.

5th Workshop, Haishen Machinery, No.11, Fourth 475000
Street, Songcheng Road,New District, Kaifeng City,
Henan Province, China
TEL: 0371-23335238

BONENG TRANSMISSION(CHANGSHA)CO.,LTD.

No. 1288 Puri Avenue, Wangcheng Economic Development 410205
Zone, Changsha City, Hunan Province, China
TEL: 0731-88386958

BONENG TRANSMISSION(USA)LLC.

1250 E 222nd Euclid, OH 44117,United Staes
TEL: 1-216-618-3099
TEL: 1-216-618-0138

